

R. C. Williams

2-18-81

**INSTALLATION, OPERATION
AND
MAINTENANCE**

**SWAN MODEL HF-700-S
SINGLE SIDEBAND
TRANSCEIVER**



TABLE OF CONTENTS

Para.	Page	Para.	Page
SECTION I – INTRODUCTION		SECTION IV – CIRCUIT THEORY	
1-1 General	1	4-1 General Discussion	11
SECTION II – INSTALLATION		4-6 Signal Generation	11
2-1 General	3	SECTION V – MAINTENANCE	
2-3 Pre-Installation Inspection	3	5-1 Alignment	14
2-7 Power Supply	3	5-3 Receiver Alignment	14
2-11 Antenna	3	5-5 Transmitter Alignment	14
2-14 Microphone	4	5-7 VFO Amplifier Plate Circuit	14
2-16 External Speaker Connections	4	5-9 Transmitter Mixer and Driver Plate Circuit	14
2-19 Internal Speaker	4	5-10 Procedure	14
2-21 Auxiliary Switching	4	5-12 Carrier Frequency Adjustment	15
2-23 V6 Output	5	5-13 P.A. Neutralization	15
2-25 External VFO Connection	5	5-15 VFO Alignment	15
SECTION III – OPERATION		5-18 Frequency Calibration	15
3-1 General	6	5-20 Dial Set	15
3-3 Receiver	6	5-22 S-Meter Adjustment	16
3-5 Receiver Operation	6	5-24 Carrier Balance	16
3-9 Receiver Tuning	6	5-27 L25 Trap Adjustment	16
3-12 Transmitter	8	5-29 Crystal Calibrator Adjustment	17
3-13 Power Rating	8	5-31 Carrier Oscillator Coil Adjustment	17
3-16 Power Amplifier Plate Dissipation	8	SECTION VI – PARTS LIST	
3-19 Transmitter Tuning	8	6-1 General	24
3-21 Tuning Steps	9		
3-22 External VFO Operation	10		

LIST OF ILLUSTRATIONS

Figure 2-1. Mobile Mounting of Model HF-700-S Transceiver	5
Figure 4-1. I.F. Filter Response Characteristics	11
Figure 4-2. Block Diagram, Model HF-700-S in Transmit Mode	12
Figure 4-3. Block Diagram, Model HF-700-S in Receive Mode	12
Figure 5-1. Top View of HF-700-S Showing Adjustments and Tube Locations ..	20
Figure 5-2. Bottom View of HF-700-S Showing Adjustments	21
Figure 5-3. Schematic Diagram, Model HF-700-S Transceiver	22/23

LIST OF TABLES

Table 1-1. Specifications, Swan Model HF-700-S	1
Table 2-1. Power Connections	3
Table 3-1. Front Panel Controls and Indicators	7
Table 5-1. VFO Plate Coil Tuning	14
Table 5-2. Bandswitch and P.A. Grid Tuning	14
Table 5-3. V.F.O. Operating Frequencies	16
Table 5-4. Troubleshooting Guide	16
Table 5-5. Voltage Chart	18
Table 6-1. Parts List	24

SECTION I

INTRODUCTION

1-1 GENERAL

1-2 The Swan Model HF-700-S Transceiver together with its accessories and optional equipment, is designed to be used in either CW or SSB modes on all portions of the 80, 40, 20, 15 and 10 meter amateur radio bands. Many of the MARS frequencies may also be covered by using the Model 510-X oscillator accessory

1-3 The HF-700-S generates a single sideband signal by means of a crystal lattice filter, and the transceiver operation automatically tunes the transceiver to the received frequency. Provisions are included in the transceiver for operation on either upper or lower sideband.

1-4 Basic circuitry of the single conversion design has been proven in several thousand of the popular Swan transceivers. Mechanical, electrical and thermal stability is exceptionally high. All oscillators are temperature compensated and

voltage regulated. Push-to-talk operation is standard, with provision for plugging in the Model VX-2 accessory VOX unit for automatic voice control and CW semi-break-in.

1-5 Operation may be fixed station, portable or mobile. Power input exceeds 500 watts, PEP, on single sideband and 360 watts on CW. The HF-700-S includes automatic gain control (AGC), automatic level control (ALC), grid block keying, CW sidetone monitor and provisions for break-in CW.

1-6 Recommended power supplies are the Model PSU-3A for 117-230 volts AC operation and the 14-117 for 12-14 volts DC. These power supplies, as well as other accessories, are described in later sections of this manual.

1-7 Specifications for the Swan Model HF-700-S are listed in Table 1-1.

Table 1-1. Specifications, Swan Model HF-700-S.

Frequency Ranges	80 Meters 3.5 to 4 MHz. 40 Meters 7.0 to 7.450 MHz 20 Meters 14.0 to 14.450 MHz 15 Meters 21.0 to 21.450 MHz 10 Meters 28.0 to 29.7 MHz
Power Input	Single Sideband, Suppressed Carrier: 550 watts, PEP input. CW: 360 Watts, DC input.
Distortion	Meets FCC requirements for spectral purity.
Unwanted Sideband Suppression	Unwanted sideband down more than 50 db.
Carrier Suppression	Carrier suppression greater than 60 db.
Receiver Sensitivity	Less than 0.5 microvolt at 50 ohms impedance for signal-plus-noise/noise ratio of 10 db.
Audio Output And Response	Audio output, 4 watts to 3.2 ohm load. Response essentially flat from 300 to 3000 Hz in both receive and transmit.
Transmitter Output	Wide-range Pi-L network output matches antennas essentially resistive from 15 to 500 ohms impedance with coarse and fine load adjustment.
Amplified ALC	Limits modulation level.
Audio Sidetone	For CW Monitoring.
Plug In VOX	Optional accessory. Also provides break-in CW.
Front Panel Controls	AF-RF Gain, Sideband Selector, CAL-REC-TRANS-CW-TUNE, Mic Gain, Band-switch, Carrier Balance, P.A. Grid Tune, P.A. Load Coarse, P.A. Load Fine, VOX-PTT switch, CW Filter Selectivity switch, Dial Set, Output Level, 25-100 KHz Calibration switch.

(Continued)

Table 1-1. (Continued)

Rear Panel Controls and Connections	Bias potentiometer, CW Key jack, Jones plug power connector, VOX connector, Antenna jack, S-Meter zero, Auxiliary relay switching, Outboard VFO connector, Headphones.
Vacuum Tube Complement	<p>V1 6EW6 VFO Amplifier V2 12BE6 Transmitter Mixer V3 6GK6 Driver V4 6MJ6 Power Amplifier V5 6MJ6 Power Amplifier V6 6CB6A Receiver RF Amplifier V7 12BE6 Receiver Mixer V8 12BA6 First IF Amplifier V9 12BA6 Second IF Amplifier V10 12AX7 Product Detector/Receive Audio V11 6BN8 AGC/ALC Amplifier V12 6GK6 Audio Amplifier V13 12AX7 Mic. Amplifier/Transmit Audio</p>
Integrated Circuits	<p>MC-1458P1 CW Filter MC-1496 Bal. Modulator 7400 Calibrator 7404 Calibrator 7490 Calibrator</p>
Diode And Transistor Complement	<p>Q1 VFO Q2 Emitter Follower Q3 Carrier Oscillator CR1 Relative Output Diode CR2 Overload Diode CR3 Overload Diode CR4- CR6 AGC Diodes CR7 CW Switching Diode CR8 CW Switching Diode CR9 Zener CR10 Relay Silencing Diode CR11 Zener CR12 Zener</p>
Power Requirements	<p>Filaments 12.6 volts, 6.7 amps, ac or dc. Relay 12 volts dc, 250 ma. Bias -110 volts dc, 100 ma. Med. Voltage 275 volts dc, 150 ma. High Voltage 800 volts dc, 1A Peak Transmit.</p>
Dimensions	5-1/2 inches high by 13 inches wide by 11 inches deep. (14 cm x 33 cm x 28 cm).
Weight	17-1/4 pounds. (7.82 kg).

SECTION II

INSTALLATION

2-1 GENERAL

2-2 Installation of the Swan Model 750-CW is not at all difficult and involves only the placement of the transceiver in its operational area (fixed or mobile), connection of power (either 117 volts AC, or 12 volts DC), and the connection to an antenna. The following paragraphs are, therefore, devoted to the installation requirements involving microphones, fixed and mobile operation and recommended antenna types.

2-3 PRE-INSTALLATION INSPECTION

2-4 Prior to installation of the Model HF-700-S, verify that the power cord is removed from the rear panel connector. Then remove the cover of the unit (three screws on either side of the cabinet).

WARNING

HIGH VOLTAGE, dangerous to life, is present at the plate connection of the power amplifier tubes whenever the power supply is energized.

2-5 Locate the P.A. compartment and remove the packing material around the P.A. tube. Inspect the transceiver for any damage that may have been incurred during shipment. If in-shipment damage is evident, contact the Swan dealer from whom you purchased the transceiver. If the unit was shipped to you by common carrier, contact the carrier's agent. Do not return the unit to the factory for repair of damage incurred in shipment before carrier's agent has authorized repairs. Also, equipment should not be returned to the factory for repair at any time without prior authorization by telephone or letter. Prior authorization insures that your unit will be properly identified and handled on receipt and returned to you with the least possible delay.

2-6 Since the installation and tune up of the transceiver, as described in the following paragraphs, requires a knowledge of the operating procedures, it would be well to review the operation section of this manual prior to proceeding with the installation instructions.

2-7 POWER SUPPLY

2-8 AC Operation. The Swan Model PSU-3A and PSU-4 Power Supplies provide all the necessary voltages required by the transceiver for AC operation. The supplies come equipped with a pre-wired plug and cable that plugs into the transceiver. The Model 117XC and 230-XC Power Supplies may also be used without modification.

2-9 DC Operation. The Model 14-117 supply for mobile operation includes all necessary cables, connector plug, fuses and installation hardware. The Jones plug for connection to the transceiver is furnished with the unit.

Table 2-1. Power Connections.

	Pin	Nominal	Minimum	Maximum
High Voltage	8	800 VDC 800 Ma.	600 VDC Low Pwr.	1200 VDC HI Pwr.
Medium Voltage	10	275 VDC 150 Ma.	225 VDC	325 VDC
Bias Voltage	8	-110 VDC 100 Ma.	-100 VDC	-130 VDC
Filament Voltage	4	12.6* 6.7 Amp.	11.5 V	14.5 V
Relay Voltage	5	12VDC 250 Ma.	10 VDC	14.5 VDC
*AC or DC				

2-10 Power requirements for the Swan Model HF-700-S are listed in Table 2-1. Pin connections to the Jones type power connector are listed as an aid in connecting other brands or "home brew" supplies.

2-11 ANTENNA

2-12 Fixed Station. Any of the common antenna systems designed for use on the high frequency amateur bands may be used with the Swan transceiver, provided the input impedance of the transmission line is not outside the capability of the pi-L output matching network. The transmission line should be of the coaxial cable type. An antenna system which shows a standing wave ratio of less than 4:1 when using 50 or 75 ohm coaxial transmission line, or a system that results in a transmission line input impedance that is essentially resistive and between 15 and 500 ohms, will take power from the transceiver with little difficulty. If open-wire or balanced type transmission line is used with the antenna, a suitable antenna tuner is recommended between the transceiver and the feed line. Methods of construction and operating such tuners are described in detail in the ARRL Antenna Handbook and similar publications. For operation on the 75 and 40 meter bands, a simple dipole antenna, cut to resonance in the most used portion of the band, will perform satisfactorily. For operation on the 10, 15 and 20 meter bands, the efficiency of the station will be greatly increased if a good directional rotary antenna is used. Remember that even the most powerful transmitter is useless without a proper and efficient antenna system.

2-13 Mobile Station. Mobile antenna installations are critical, since any mobile antenna for use on the high

frequency bands represent a number of compromises. Many amateurs lose the efficiency of their antenna through improper tuning. Points to remember about the mobile antenna used with the Swan HF-700-S are:

1. The "Q" of the antenna loading coil should be as high as possible. There are several commercial models available which use high "Q" coils, including the Swan Model 45 five band "Swantenna".
2. The loading coil must be capable of handling the power of the HF-700-S without over-heating. In the TUNE mode, the power output of the transceiver may exceed 300 watts. Wide spaced, heavy wire loading coils are essential.
3. The SWR bridge is a useful instrument, but unfortunately it is quite often misunderstood, and overrated in importance. Basically, the SWR bridge will indicate how closely the antenna load impedance matches the transmission line. With long transmission lines, such as will be used in many fixed station installations, it is desirable to keep the impedance match fairly close in order to limit power loss. This is particularly true at the higher frequencies. The longer the line, and the higher the frequency, the more important SWR becomes. However, in mobile installations, the transmission line seldom exceeds 20 feet in length, and an SWR of even 4 to 1 adds very little power loss. The only time SWR will indicate a low figure is when the antenna presents a load close to 50 ohms, but many mobile antennas will have a base impedance as low as 15 or 20 ohms at their resonant frequency. In such cases, SWR will indicate 3 or 4 to 1, and yet the system will be radiating efficiently.
4. The really important factor in your mobile antenna is that it should be carefully tuned to resonance at the desired frequency. The fallacy in using an SWR bridge lies in the fact that it is sometimes possible to reduce the SWR reading by detuning the antenna. Field strength may actually be reduced in an effort to bring SWR down. Since field strength is the primary goal, we recommend a Field Strength Meter for antenna tuning.
5. For antenna adjustments, the HF-700-S should be loaded lightly to about 100 ma. cathode current instead of the usual 500-800 ma. This will limit tube dissipation during adjustments and will also help reduce interference on the frequency. In any case, do not leave the transmitter on for very long at one time. Turn it on just long enough to tune and load and get a field strength reading.
6. Start with the antenna whip at about the center of its adjustment range. Set the VFO to the desired operating frequency and then adjust P.A. TUNE for dip, and P.A. LOAD for 100 ma. Then observe the field strength reading. The Field Strength Meter may be set on top of the dash, on the hood, or at an elevated location some distance from the car.

7. Change whip length a half-inch, or so, at a time. Retune the P.A. for 100 ma. loading each time, and check field strength. Continue this procedure until the point of maximum field strength is found. This adjustment will be most critical on 75 meters, somewhat less critical on 40, etc., until on 10 meters the adjustment will be quite broad. After tuning the antenna to resonance, load the P.A. to full power.

2-14 MICROPHONE

2-15 The microphone input is designed for high impedance microphones only. The choice of microphone is important for good speech quality, and should be given serious consideration. The crystal lattice filter in the transceiver provides all the restriction necessary on audio response, and further restriction in the microphone is not required. It is more important to have a microphone with a smooth, flat response throughout the speech range. The microphone plug must be a standard 1/4 inch diameter three-contact type. The tip connection is for push-to-talk relay control, the ring connector is the microphone terminal, and the sleeve is the common chassis ground. The microphone manufacturer's instructions should be followed in connecting the microphone cable to the plug. With many microphones, the push-to-talk button must be pressed to make the microphone operative. For VOX operation, this feature may be disabled, if desired, by opening the microphone case and permanently connecting the contacts which control the microphone.

2-16 EXTERNAL SPEAKER CONNECTIONS

2-17 Receiver audio output from the HF-700-S is at 4 ohms voice coil impedance. This output is terminated at pin 12 of the Jones power connector and at the headphone jack on the rear of the transceiver. When using the PSU-3A matching power supply, connection is automatically made to the speaker which is built into the supply.

2-18 For mobile installations, an external speaker may be connected to pin 12 of the Jones connector. The other speaker terminal goes to pin 6, or chassis ground. The speaker may be any good 4 ohm permanent magnet type in the 4 inch or larger size.

2-19 INTERNAL SPEAKER

2-20 Provision is made for installation of a standard 3 x 5 inch speaker inside the HF-700-S. This may be desirable particularly in mobile installations. The speaker mounts on the left side of the chassis and terminal lugs are provided near the 6GK6 audio output tube. Simply connect wires from the 2 speaker lugs to these terminals. One is "hot" and the other is ground.

2-21 AUXILIARY SWITCHING

2-22 A 3-lug terminal strip on the rear panel of the HF-700-S provides for switching of external accessories. They are marked R, C and T. R and C are connected when receiving. C and T are used when the Swan Mark II Linear Amplifier is used.

2-23 V6 OUTPUT

2-24 A phone type output jack is provided on the rear panel of the HF-700-S for connecting the antenna system to an auxiliary receiver. Thus, a separate receiver may be used, if desired, with the same antenna system. V6 is the 6CB6A R.F. Amplifier stage in the HF-700-S receiver circuit. It serves as a pre-amplifier for the auxiliary receiver.

2-25 EXTERNAL VFO CONNECTION

2-26 An external VFO may be connected to the Swan Model 750-CW Transceiver to permit semi-duplex operation where

transmission and reception are on different frequencies. The Accessory jack on the rear panel is provided for connecting the external VFO. Generally, the external VFO will be used to generate the local oscillator signal during reception. 12.6 VAC, -12 VDC, +215 VDC and +215R (+215 receive only) are available at the Accessory jack to provide power for the external VFO. The design should be such that control of the transmitting frequency is returned to the internal VFO when the transmitter is keyed. Coaxial cables should be used for the R.F. signals running to and from the external VFO. The external VFO should provide an input signal of 1.5V RMS within the frequency ranges shown in Table 5-3. Consult Figure 5-3, the HF-700-S schematic diagram, for information on connections for the external VFO.

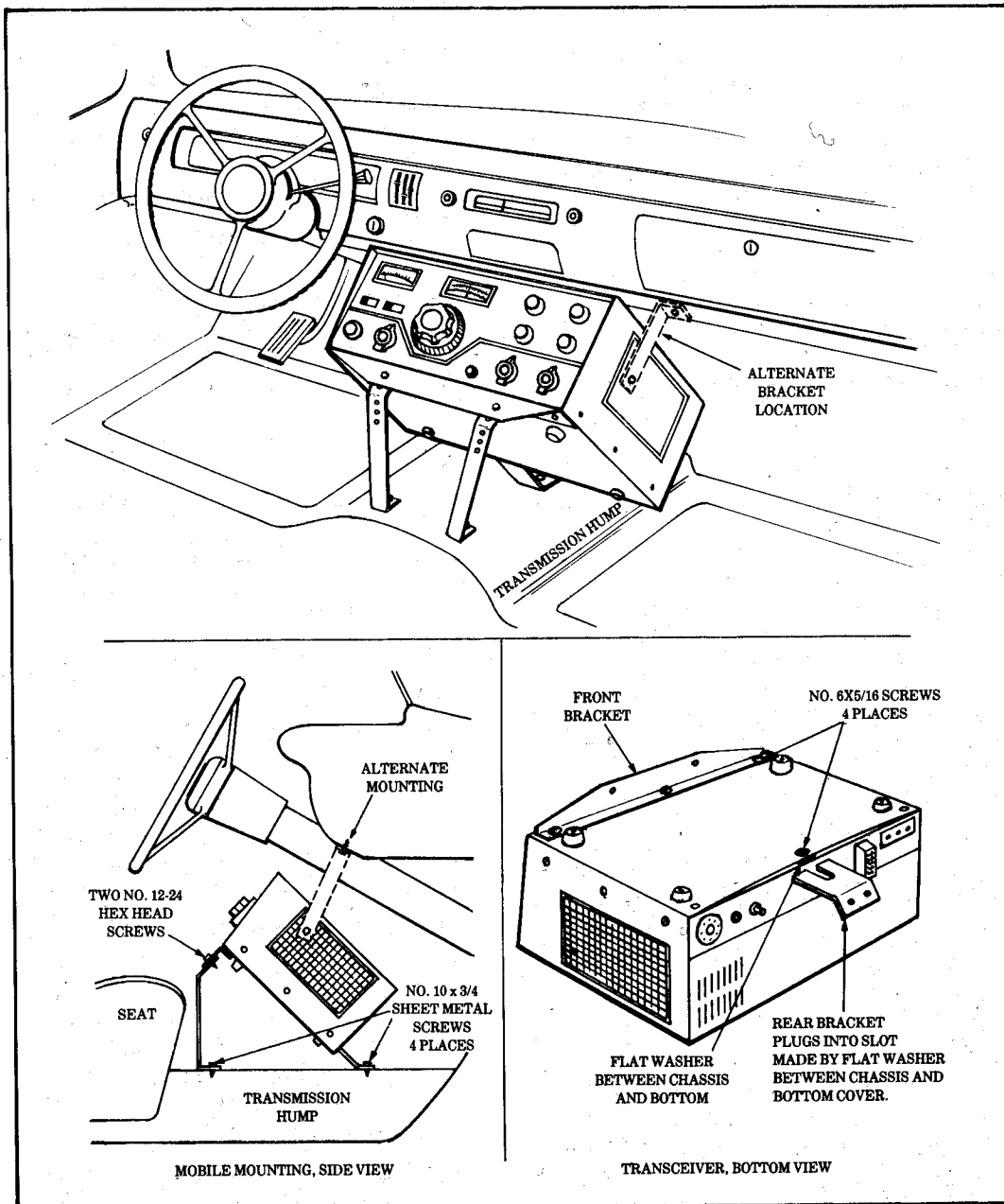

Figure 2-1. Mobile Mounting of Model HF-700-S Transceiver.

SECTION III OPERATION

3-1 GENERAL

3-2 Refer to Table 3-1 for a description of the function of each front panel control and indicator. Before proceeding to apply power to the HF-700-S, perform the following:

1. Verify that the packing has been removed from around the P.A. tubes.
2. Rotate the CAL-REC-TRANS-CW-TUNE switch counter-clockwise to REC.
3. Rotate the AF GAIN control counterclockwise to OFF.
4. Verify that a wire is connected from earth ground to the ground stud on the rear chassis panel.
5. Verify that an antenna is properly connected. (See Section II).
6. Verify that the power supply cable is connected to the rear panel Jones connector.
7. Connect the HF-700-S to the proper voltage source.

WARNING

Dangerous high voltage is present on the plate connections of the power amplifier tubes whenever the power supply is energized. Never turn power on when the power amplifier cover is removed. High voltage is also present at pin 8 of the power plug.

3-3 RECEIVER

3-4 Whenever the function switch is in the RECEIVE or CALIBRATE position, or at any time the transmitter is not in TRANSMIT, all circuits used in transmitting are disabled through circuits controlled by relays K1 and K2. The relays are energized for transmitting and de-energized for receiving. Relay K2, when de-energized, allows signals from the transmitting tank circuit and antenna to be fed to the receiver RF amplifier, V6 (see Figures 4-1 and 4-2), where they are amplified and then fed to the control grid of the Receiver Mixer, V7. The local oscillator signal from the VFO Amplifier is now used to heterodyne the received signal to the IF frequency. All IF amplification is accomplished at this frequency, nominally 5500.0 KHz, through amplifiers V8 and V9. In the Product Detector, V10-A, the signal is heterodyned with the carrier frequency generated by Carrier Oscillator, Q3. The resultant audio signal is then amplified by V10-B, which then couples to V11, the AGC Amplifier, and V12, the Output Audio stage. When operating in the CW mode, the signal is passed through a two-stage active filter. The CW FILTER switch selects an 80 or 100 Hz passband.

3-5 RECEIVER OPERATION

3-6 Rotate the AF GAIN control clockwise to about the 3 o'clock position. The power switch will operate applying filament, relay, bias, medium and high voltages to the transceiver.

3-7 Wait approximately one minute to allow the tube filaments to reach operating temperature. During this period, perform the following steps:

1. Rotate the BANDSWITCH to desired band.
2. Rotate MIC. GAIN fully counter-clockwise.
3. Rotate CAR. BAL. control to the midscale position, with white dot on knob aligned with the long index mark on the panel.
4. Preset P.A. PLATE control fully counter-clockwise.
5. Preset P.A. GRID control to mid-position.
6. Preset P.A. LOAD FINE fully counter-clockwise.
7. Preset P.A. LOAD COARSE to position 1.
8. Set tuning dial to desired frequency.
9. Set RF GAIN control fully clockwise.
10. CW FILT. to OFF.

3-8 Carefully adjust the P.A. GRID and P.A. PLATE controls for maximum receiver noise. Note that the P.A. GRID control resonates the transmitter driver stages and the receiver RF amplifier plate circuit. The P.A. PLATE and P.A. LOAD controls adjust the input and output capacitors in the transmitter power amplifier final plate circuit, as well as the receiver RF amplifier grid circuit. Proper adjustment of these controls in the receive position will result in approximately resonant conditions in the transmitter stages.

3-9 RECEIVER TUNING

3-10 The tuning dial of the HF-700-S has a scale reading from 0 to 450 which is used on 40, 20 and 15 meters. Above this scale is a separate calibration for 80 meters, reading from 3500 to 4000 KHz. The lowest scale is the 10 meter scale, reading from 28 to 29.7 MHz.

3-11 Precise tuning of a single sideband signal is very important. Do not be satisfied to merely tune until the voice can be understood, but take the extra care of setting the dial

Table 3-1 Front Panel Controls and Indicators.

CONTROL	FUNCTION
On-Off Switch (On AF Gain Knob)	Turns power supply on and off.
Cal-Rec-Trans-CW-Tune	<p>Calibrate: All voltages are applied to transceiver. Ground is applied to pins 12 and 13 of A1 and removed from cathode of V13A.</p> <p>Receive: All voltages applied to transceiver.</p> <p>Transmit: 12 volt DC circuit through relays RY1 and RY2 is completed and tubes used only in receive are biased to cutoff. Meter reads P.A. cathode current.</p> <p>CW: All circuits for transmit are energized, as above. Capacitor C171 in the carrier oscillator is switched into the circuit. Carrier must be inserted with the CAR. BAL. control. Meter reads P.A. Cathode current.</p> <p>Tune: Same as CW except that carrier is fully inserted. Meter reads relative output.</p>
Microphone Gain	Controls potentiometer R132 in the grid of V13-A. Controls amount of audio to the balanced modulator.
Car. Balance	Controls potentiometer R122 in the balanced modulator and permits nulling out the carrier.
RF Gain	Controls variable resistor R45. Controls gain of receiver mixer, R.F. Amplifier and I.F. Amplifiers.
AF Gain	Controls potentiometer R84 in grid circuit of V12 A.F. Output. Controls Audio volume.
Main Tuning	Controls C16 in frequency determining tank circuit of VFO.
Panel Meter	Reads S-Units in Receive mode, P.A. Cathode Ma. in Trans. and CW modes and relative output in Tune mode.
Main Bandswitch	Switches plate coils and associated capacitors of VFO, VFO Amplifier, V1, Transmitter Mixer, V2, and Driver, V3. Also switches tank coil of pi-L coupling system and associated capacitors in P.A. output tank.
Output Level	Adjusts meter reading when in Tune mode. Note that this control has no effect on power output, but determines only the relative meter reading.
Sideband Selector	Selects Normal or Opposite sideband. Normal is LSB on 80 and 40 meters, USB on 20, 15 and 10 meters.
P.A. Bias (Rear Control)	Adjusts idling cathode current of Power Amplifier.
S-Meter Zero (Rear Control)	Adjusts S-Meter to zero reading with antenna disconnected.
PTT-VOX	Set to PTT position for press-to-talk operation or VOX position for voice control with VX-2 accessory.
Cal. 100 KHz-25 KHz	Selects 100 KHz or 25 KHz calibration markers.
P.A. Grid	Controls C35-A and C35-B in plate tanks of transmitter mixer and driver.
P.A. Plate	Controls C64-A and C64-B in Plate Circuit of Power Amplifier Tubes.
P.A. Load, Fine	Controls C76-A and C76-B in pi-L network to match impedance of output load. Tunes input to Receiver R.F. Amplifier.
P.A. Load, Coarse	Switches in progressively more capacitance in parallel with P.A. LOAD, FINE.
CW Filter Selectivity	Selects desired CW bandpass for rejection of adjacent signals.

to the exact spot where the voice sounds natural. Above all, avoid the habit of tuning so that the voice is pitched higher than normal. This is an unfortunate habit practiced by quite a number of operators. The following points help to explain the effects of mistuning:

1. If you tune so the received voice is higher than the normal pitch, you will then transmit off frequency, and your voice will sound lower than normal pitch to the other station. He will probably retune his dial to make you sound right. If you keep this up, you will gradually waltz one another across the band. If both of you are mistuning to an unnatural higher pitch, you will waltz across the band twice as fast. (And someone will no doubt be accused of frequency drift.)
2. Mistuning results in serious harmonic distortion of the voice, and should be quite noticeable to the average ear. Some will claim that if they don't know how the other person's voice actually sounds, they can't tune him in properly, but this is not true. With a little practice, it is fairly easy to tell. Some voices are relatively rich in harmonics, and are easier to tune in than a person with a "flat" voice. Also, a transmitter which is being operated properly with low distortion will be easier to tune in than one which is being overdriven and is generating excessive distortion. There is no mistaking when you have a station tuned right on the nose. It will sound just like "AM," so to speak. Mainly, avoid the habit of tuning so everyone sounds higher than normal pitch, or like Donald Duck.

3-12 TRANSMITTER

3-13 Power Rating

3-14 The Swan HF-700-S is capable of ⁴⁵⁰550 watts, PEP, input under steady state, two-tone conditions, when operated with any of the recommended power supplies. The peak envelope power, when voice modulated, is considerably greater, typically 550 watts, or more.

3-15 Recommended power ⁷⁵⁰supplies produce a no-load plate voltage of approximately 925 volts. Under TUNE conditions, or CW operation, this voltage will drop to approximately 700 volts. Under steady state two-tone modulation, the voltage will drop to approximately 750 volts. If the power amplifier idling current is 50 ma, and the two-tone current, just before flat-topping, is 400 ma, the peak two-tone current will be 600 ma. Under these conditions the PEP input will be 750 volts times 600 ma., or 450 watts. Under voice modulation, because average power is considerably less, the power amplifier plate and screen voltages will be maintained higher, even during voice peaks, by the power supply filter capacitors. Peak plate current, therefore, will also be higher than with two-tone test conditions. Under typical operating conditions, peak plate current before flat-topping may, on some bands, be as high as 1 amp at over 800 volts, resulting in an input of over 800 watts, PEP. Readings of cathode current will not reflect this over 800 watt power input, however, because of the damping in the cathode current meter. Cathode current readings under normal voice input should not exceed 225 ma. on occasional peaks.

3-16 Power Amplifier Plate Dissipation

3-17 There is often a misunderstanding about the plate dissipation of tubes operated as AB1 amplifiers under voice modulation. In the Swan HF-700-S, while in the transmit position, and with no modulation, the plate voltage will be 890 volts, the plate current about 50 ma., and the power input will be 45 watts.

3-18 Average voice power is from 10 to 20 db below peak voice power. Normally some peak clipping in the power amplifier can be tolerated, and a peak-to-average ratio of only 6 db may sometimes occur. Under such conditions, the average power input will be 125 watts and average plate current will be 156 ma. With power amplifier efficiency of 65 percent, plate dissipation will be 44 watts, or 22 watts per tube. The 6MJ6 is rated at 30 watts, continuous duty cycle. Thus, it can be seen that under normal operating conditions, the power amplifier tubes in the Swan Model HF-700-S are not being driven very hard. Note, however, that the proper modulation level must be maintained by correct setting of HIC GAIN and that the length of time in TUNE mode should be limited to not more than 30 seconds at a time.

3-19 Transmitter Tuning

3-20 Special Notes: Read Carefully. Be sure that you understand and remember these notes when tuning the transmitter.

1. The most important detail to keep in mind when tuning the transmitter portion of your Swan Transceiver is that the P.A. PLATE *must be resonated as quickly as possible!* The P.A. tubes are dissipating all the power input when not in resonance, and can be permanently damaged in just a few seconds. Once resonance has been established, the P.A. tubes can operate at full power input for a considerable length of time, although we recommend 30 seconds as a safe maximum during tuneup. It is most important to realize that the 30 second limit assumes that the P.A. PLATE has been *immediately* resonated. This rule applies to all transmitters.
2. P.A. Plate resonance may be accomplished by (1) tuning for the "dip" in P.A. cathode current, or (2) tuning for maximum transmitter output, depending on which circuit is being metered.
3. In the HF-700-S, you are reading P.A. cathode current when in the Press-To-Talk (PTT), TRANS or CW mode. P.A. PLATE must always be tuned for the "dip" in meter reading when in the TEST or CW mode.
4. When the HF-700-S Function switch is in the TUNE position, the meter circuit is automatically switched to indicate transmitter output level. So, P.A. PLATE must always be tuned for maximum meter reading when in the TUNE mode.

Read items (3) and (4) over carefully to be sure you understand.

5. The OUTPUT LEVEL control located on the right hand side of the panel meter adjusts the meter reading to a convenient level when in "TUNE" mode. It is important to realize that this control has no effect whatsoever on transmitter power. It is required because of wide variations in meter readings caused by various antenna loads, and different frequency bands. When in "TUNE" mode, the meter reading is strictly a relative indication of power output.
6. When first tuning the HF-700-S, you may find the 30 second time limit too short. In that event, switch back to REC mode for a minute or two. Then resume tuning procedures. With experience, transmitter tuning will require only 10 or 15 seconds. Do not tune more often than necessary. You should not have to retune except when changing bands or antennas. The P.A. tubes will last for many months, or even years, of normal operation, but constant tuning at full grid drive will shorten their life considerably.

CAUTION

The HF-700-S may be tuned to frequencies outside the amateur bands. Do not tune or operate the transmitter unless you are within your permitted band limits.

3-21 Tuning Steps

1. Place the front panel controls in the positions indicated below:

P.A. PLATE — 9 O'clock.

COARSE LOAD — (3.5 MHz Band) Position 3.
 (7.0 MHz Band) Position 3.
 (14.0 MHz Band) Position 5.
 (21.0 MHz Band) Position 6.
 (28.0 MHz Band) Position 6.

FINE LOAD — 12 O'clock.

P.A. GRID — 12 O'clock.

MIC GAIN — Minimum.

CAR BAL — 12 O'clock.

OUTPUT LEVEL — Maximum Clockwise.

MODE SWITCH — REC position.

2. Key transmitter and adjust CAR BAL for minimum meter indication. Unkey transmitter.
3. Key transmitter and adjust P.A. BIAS control on rear panel for a meter reading of 50 milliamperes. Unkey transmitter.

4. Key transmitter and adjust CAR BAL control for a slight indication on the meter then *quickly peak the P.A. GRID* control for maximum output. Unkey transmitter.
5. Place Mode switch in TUNE position. Adjust CAR BAL for slight meter indication and *quickly peak P.A. TUNE and P.A. GRID* controls for maximum indication on meter. Return Mode switch to REC.
6. Set CAR BAL control to its full clockwise position.
7. Place Mode switch in TUNE position and *quickly adjust P.A. TUNE and FINE LOAD* controls, one after the other, for maximum indication on meter. Repeat adjustments as they interact. Return Mode switch to REC position.

NOTE

Panel meter reads relative output in TUNE position and OUTPUT LEVEL control adjusts meter sensitivity only. Adjust OUTPUT LEVEL control, if necessary, to keep meter on scale.

NOTE

If FINE LOAD goes to its full clockwise position during tuning, increase the COARSE LOAD switch position by one step. If FINE LOAD goes fully counter clockwise, decrease COARSE LOAD switch position by one step, i.e. from 6 to 5.

CAUTION

Each step of the foregoing procedure must be accomplished within 30 seconds to prevent overheating of the final amplifier tube plate.

8. Set the CAR BAL control to 12 O'clock and the OUTPUT LEVEL control to its full clockwise position.
9. Place the Mode switch in the TUNE position and *quickly adjust CAR BAL* for minimum indication on the meter. This effectively balances out the carrier. Return Mode switch to REC.

NOTE

It is best that the set be loaded to the power level intended for use. In steps 6 and 7, the CAR BAL control should be set to give the desired power output and the set loaded at that level. Either full clockwise or full counter clockwise position of the CAR BAL control corresponds to full output power.

NOTE

Initial control settings can also be found by peaking the P.A. PLATE, P.A. GRID and FINE LOAD controls for maximum noise in the receiver output

while the HF-700-S is connected to the antenna. The initial COARSE LOAD setting listed in (1) above should be used. The control settings obtained in this manner will closely approximate the final transmitter tuning positions.

10. **Voice Transmission.** Press the push-to-talk button on the microphone and while speaking into the microphone, slowly rotate the MIC GAIN control until occasional peak readings of 200 to 225 milliamperes are obtained. With most microphones, the MIC GAIN controls will be set between 9 and 12 o'clock, but it may vary considerably. The amplified ALC circuit will help limit cathode current to about 225 milliamperes, but turning MIC GAIN up too high will still produce flat-topping and spurious signals, so it is important to hold it down. The meter is quite heavily damped, and its reading with average voice modulation may not look very impressive, but the voice peaks are going well over the 550 watt power rating of your Swan 750-CW Transceiver. Note that the transceiver will not modulate with the Function Switch in the CAL. position.
11. **CW Operation**
 - a. Insert a CW key in the KEY jack on the rear panel of the HF700-S. Tune the HF-700-S as in steps 1 through 7 above. A jack on the rear panel is available for connection of headphones.
 - b. In Manual CW operation, it will be necessary to switch the Function control back to REC. for receiving and then to CW for CW transmitting.
 - c. **Semi-Break-In CW.** When the VOX accessory, model VX-2 is used, break-in operation may be employed. Move the PTT-VOX switch to the VOX position and rotate the Function control to CW. Rotate the VOX GAIN control fully counterclockwise and the ANTI-TRIP control on the VX-2 to full counterclockwise position. Press the CW key to transmit. When you stop keying, the circuits will automatically switch back to the receive mode. Adjust the VX-2 DELAY control to the position that gives the desired delay time in returning to receive.
 - e. **Off-set CW Transmit Frequency.** While receiving, the carrier oscillator frequency is located 300 cycles outside the passband of the crystal lattice filter, thus providing a single heterodyne note, or "single-signal" for CW reception. When transmitting in CW mode, the carrier frequency is moved approximately 800 cycles higher, placing it well inside the passband. This frequency shift is termed "Off-set CW transmit frequency," and avoids the problems encountered when the receive and transmit frequency are exactly the same. In that type of system, when receiving CW, the receiver must be tuned off frequency several hundred cycles in order to hear an

audio beat. By providing this shift automatically in the HF-700-S, CW operation is greatly amplified. The active filter in the HF-700-S provides narrow audio passband for CW receive operation. The 100 Hz band-pass position is also useful for crowded band conditions in SSB. When using the active filter for CW operation, precise tuning of the received signal is necessary to center the desired signal in the audio passband.

12. **Sidetone Oscillator.** The sidetone oscillator circuit permits monitoring of the transmitted CW signal. The tone and strength of the sidetone can be adjusted by removing the top cover, locating the CW sidetone circuit board and adjusting the tone and volume to the desired level. The sidetone volume is independent of the setting of the audio gain control. See Figure 5-1 for location of sidetone adjustments.
13. After tuning for maximum output, it will be useful to know how much cathode current the P.A. is drawing at full power input. This will help indicate the condition of the P.A. tubes, as well as the driver stage and other tubes in the transmitter circuitry.
 - a. This may be done by switching to CW mode, and inserting full carrier with the CAR. BAL. control. The key jack circuit must be closed by a CW key for this test.
 - b. Alternately, you can check P.A. cathode current by whistling a steady tone into the microphone. It will be found that cathode current is typically 550 ma. or more on the lower bands, but will be somewhat lower on 10 and 15 meters, typically between 450-500 ma. Several factors can affect cathode current, including AC input voltage (or DC voltage in mobile use), tube condition, and circuit alignment. The reading should be used primarily as an indication of gradual change, or deterioration.

3-22 EXTERNAL VFO OPERATION

3-23 Use of an external VFO permits operation of the Model HF-700-S in a semi-duplex mode where the transmitting and receiving frequencies are different. The design of the external VFO should be such that it provides only the receiving local oscillator signal. (See paragraph 2-25). The HF-700-S internal VFO should provide the transmitting frequency control. The operator should maintain the external VFO within 100 KHz of the transmitting frequency to insure that the receiver sensitivity is maintained at maximum. (The P.A. PLATE and P.A. LOAD tuning adjustments affect receiver sensitivity. Follow the transmitter tuning steps of paragraph 3-19 when using the internal VFO. Then tune the external VFO to a frequency within 100 KHz of the frequency to which the transmitter is tuned.

SECTION IV

CIRCUIT THEORY

4-1 GENERAL DISCUSSION

4-2 The Swan HF-700-S transceiver provides single sideband, suppressed carrier transceiver operation and generates the single sideband signal by means of a crystal lattice filter. To permit a logical discussion of this mode of operation, certain definitions are necessary. In a normal AM signal, (double sideband with carrier), a radio frequency signal is modulated with an audio frequency signal. This is considered by many to be merely a case of varying the amplitude of the carrier at an audio rate. In fact, there are actually sideband frequencies generated, which are the result of mixing the RF and AF signals. These sidebands are the sum of, and the difference between the two heterodyned signals. In the detection of this conventional AM signal, the two sidebands are mixed with the carrier to recover and reproduce the audio intelligence. This is an inefficient means of transmission because only 25 percent of the transmitted power is used to transmit intelligence. There are other attendant drawbacks, also. The bandwidth of AM voice transmission is approximately 6 KHz while the actual demodulated audio is approximately 3 KHz. The result is inefficient use of the frequency band, and over half of the allotted band is unusable due to heterodynes, interference and congestion.

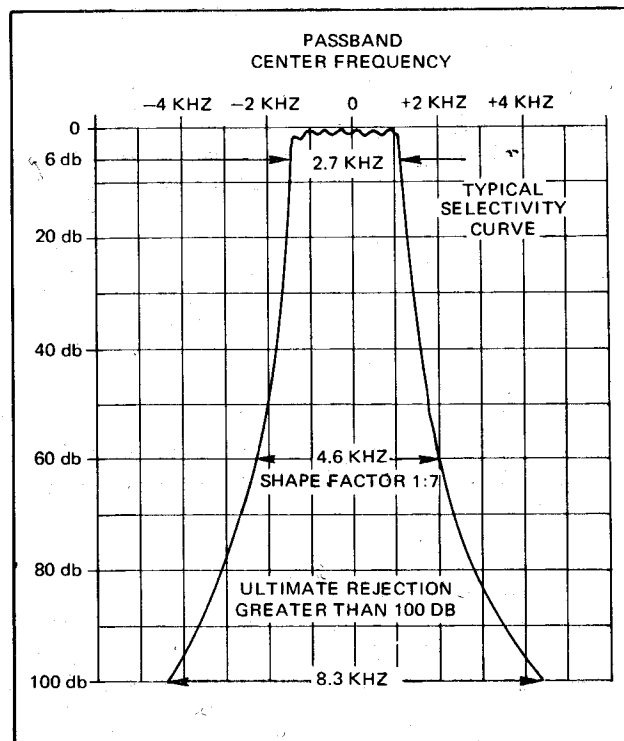

Figure 4.1. I.F. Filter Response Characteristics.

4-3 In the single sideband, suppressed carrier mode of transmission, only one of the sideband signals is transmitted. The other sideband and the carrier are suppressed to negligible levels. In addition to increasing the transmission efficiency by a factor of four, single sideband effectively doubles the number of stations or channels which can be used in a given band of frequencies.

4-4 It should be remembered that in the single sideband, suppressed carrier mode of transmission, the unwanted sideband and carrier are only suppressed, not entirely eliminated. Thus, with a transmitted signal from a transmitter with 50 db sideband suppression, the other or unwanted sideband will be present, and will be transmitted, but its level will be 50 db below the wanted sideband. When this signal is received at a level of 20 db over S9, the unwanted sideband will be present at a level of approximately S5. The same is true of carrier suppression. With carrier suppression of 60 db, and a signal level of 20 db over S9, carrier will be present at a level of approximately S3 to S4.

4-5 In the Model HF-700-S Transceiver, the single sideband, suppressed carrier signal is generated by the crystal lattice filter having the characteristics shown in Figure 4-1 and with the transmitting and receiving methods shown in the block diagrams of Figures 4-2 and 4-3.

4-6 SIGNAL GENERATION

4-7 When the push-to-talk switch on the microphone is pressed, the transmitter portion of the transceiver is activated, and it generates a single sideband, suppressed carrier signal in the following manner. Carrier is generated by a crystal oscillator using transistor, Q3. This stage operates in both the transmit and receive modes. When transmitting, the RF output of the carrier oscillator is injected into the carrier input port of an MC1496L integrated circuit. This circuit consists of an upper quad differential amplifier driven by a standard differential amplifier with dual current sources. The output collectors are cross-coupled so that full-wave balanced multiplication of the two input voltages occurs. Audio signals from the microphone amplifier, V13, are applied to the signal ports of the integrated circuit. The carrier oscillator signal acts as a switching voltage. The output applied in push-pull to T2 consists of a double sideband signal resulting from the carrier and audio signals. Carrier suppression is approximately 25 db.

4-8 The double sideband, suppressed carrier signal is then coupled from the secondary winding of T2 to the crystal

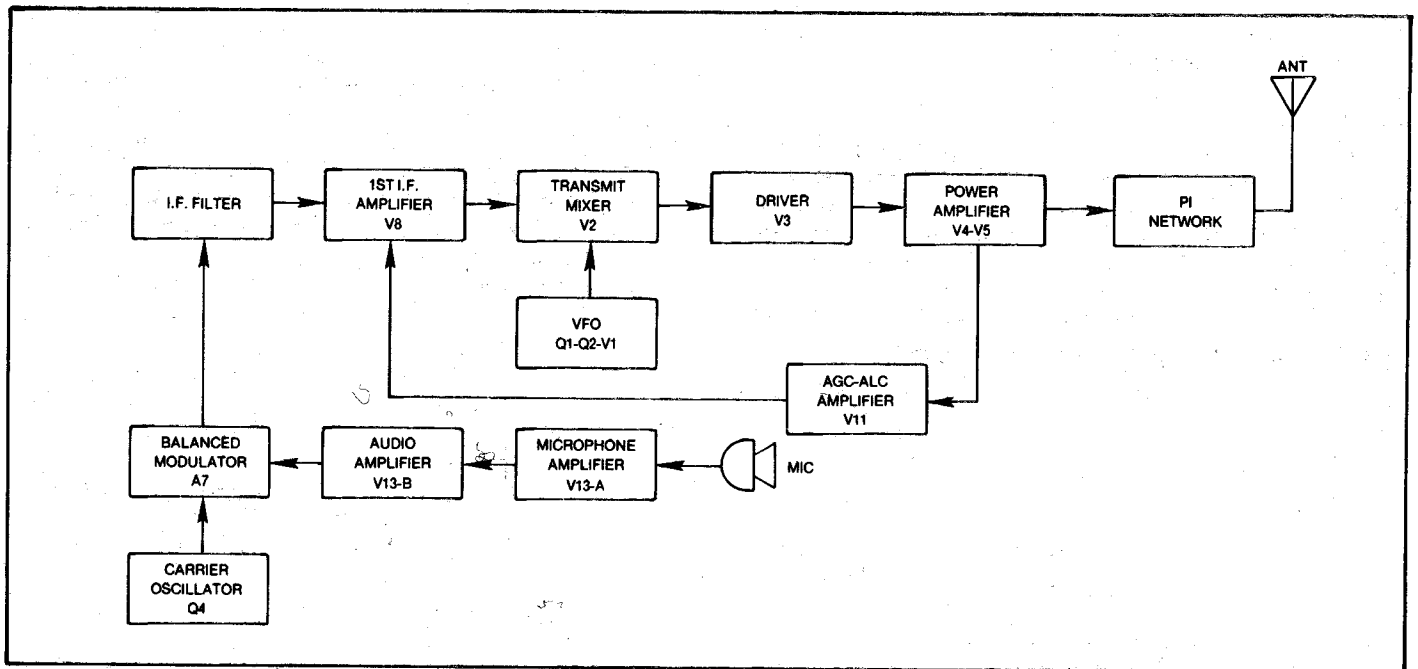

Figure 4-2. Block Diagram, Model HF-700-S in Transmit Mode.

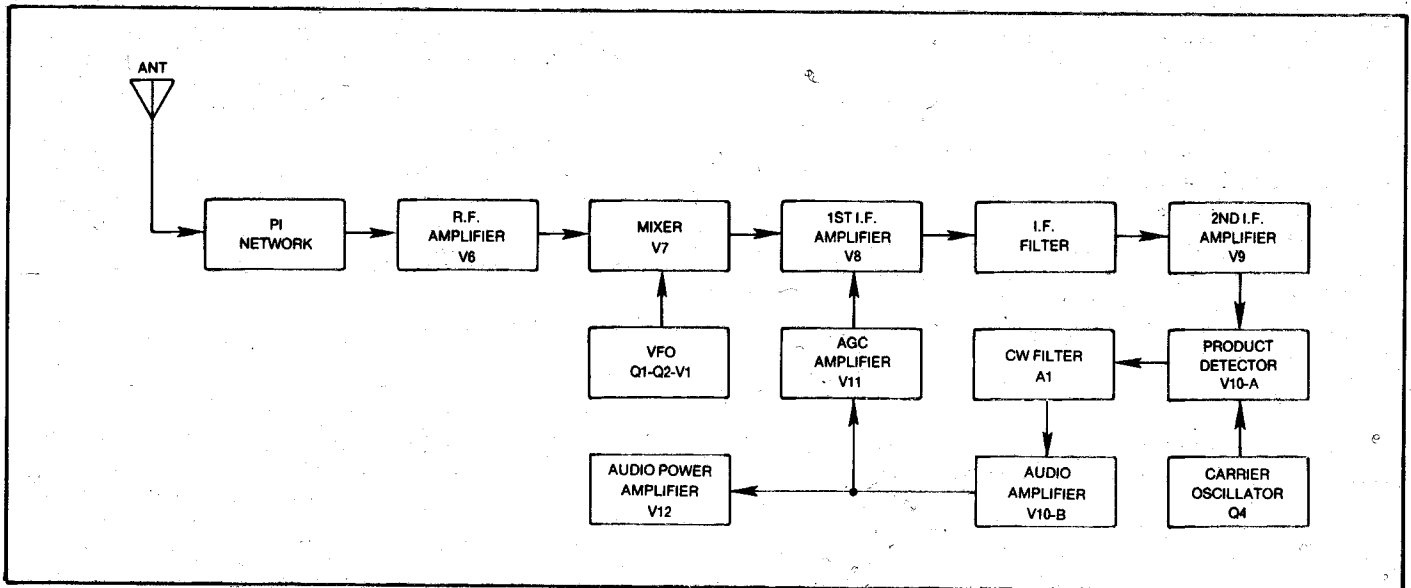

Figure 4-3. Block Diagram, Model HF-700-S in Receive Mode.

filter, which suppresses the lower sideband, and permits only the upper sideband to be fed to the First IF Amplifier, V8. The carrier frequency is generated at approximately 5500.0 KHz, normal sideband. With the opposite sideband crystal, the carrier crystal frequency will be 5503.3 KHz, and this positions the double sideband signal on the other side of the filter response curve, attenuating the upper sideband by at least 50 db. In the single conversion mixing process, these sidebands become inverted on 80 and 40 meters. Thus, the Swan 750-CW normally operates on lower sideband on 80 and 40, while on 20, 15 and 10 meters normal operation is on upper sideband.

4-9 Q1, the VFO 2N706 oscillator, operates in the common base configuration as a Colpitts oscillator. Q2, the emitter follower, is used for isolation. The extremely good regulation achieved through using zener diode regulator CR9 across the bias supply voltage, also contributes to the stability. Bandswitching is accomplished by changing the tank circuit coil. The VFO in the Model HF-700-S exhibits extremely good stability after the initial warm-up period. Drift from a cold start will be less than 1 KHz for the first hour on the 80, 40 and 20 meter bands and less than 2 KHz for the first hour on the 10 and 15 meter bands. After initial warm-up, drift will be negligible.

4-10 The single sideband, suppressed carrier signal from the first IF Amplifier is fed to the Transmitter Mixer, V2, where it is heterodyned with the VFO signal. The resultant signal at the desired transmit frequency is amplified by the Driver, V3, and the Power Amplifiers, V4 and V5. The signal from the VFO Amplifier is initiated in the transistorized VFO-Emitter Follower circuit Q1 and Q2. The signal from the VFO is routed to the VFO Amplifier, and on 40 and 80 meters, is subtractively mixed with the single sideband signal from the IF Amplifier, and results in LSB operation. On 20, 15 and 10 meters, the frequencies are additively mixed, resulting in output on the upper sideband.

4-11 When in TRANSMIT, the gain of the First IF Amplifier is controlled by an amplified ALC circuit, V11, in response to the average input power to the Power Amplifiers. This ALC system will compensate for extremely strong input signals, but does not completely eliminate the necessity of proper adjustment of the MIC. GAIN Control. This feature will help prevent the transmitter from flat-topping and spurious emissions, but considerable distortion may occur if the MIC. GAIN Control is not properly adjusted. Refer to Operating Instructions.

SECTION V MAINTENANCE

5-1 ALIGNMENT

5-2 The following procedures are given in the order performed during the factory alignment for the transceiver. For home servicing, only partial alignment may be necessary. Read all procedures carefully before commencing either partial or complete alignment. See Figures 5-1 and 5-2 for component placement. The following equipment will be required for complete alignment:

1. Audio Signal Generator.
2. 500 watt dummy load with output meter.
3. Vacuum tube voltmeter.
4. Field Strength meter.

5-3 RECEIVER ALIGNMENT

5-4 Receiver alignment involves only the adjustment of the Second IF coil and the 10 meter receiver coil. The 15, 20, 40 and 80 meter coils which affect receiver performance are also used in the transmit mode. Their adjustment is covered under "Transmitter Alignment".

1. After allowing one minute for warm-up, tune the receiver to the middle of either 15, 20, 40 or 80 meters and on a clear frequency.
2. Adjust the P.A. PLATE, P.A. GRID and P.A. LOAD front panel controls for maximum background noise.
3. Adjust IF coil L-33 for maximum background noise.
4. Switch to the center of 10 meters and adjust L-12 for maximum background noise.

5-5 TRANSMITTER ALIGNMENT

5-6 The alignment of transmitter circuits involves the adjustment of tuned circuits in the VFO amplifier, V1, the Transmit Mixer, V2 and Driver stage, V3. A dummy load should be connected to the antenna jack during this series of adjustments.

5-7 VFO Amplifier Plate Circuit

5-8 With VTVM from pin 1 of V7, Receiver Mixer, to ground, on -15 volt scale, adjust VFO Amplifier Plate Coils for peak VTVM reading on the bands at the frequencies shown in Table 5-1.

5-9 Transmitter Mixer and Driver Plate Circuit

1. Adjust P.A. BIAS control fully counterclockwise (maximum bias).

Table 5-1. VFO Plate Coil Tuning.

Band	VFO Frequency (KHz)	Dial Frequency (KHz)	Coil
80	9,300	3,800	L104
40	12,625	7,125	L103
15	15,725	21,225	L102
10	23,000	28,500	L101

Table 5-2. Bandswitch and P.A. Grid Tuning.

Band	P.A. Grid	Dial Freq.	Adjust	
80	12 O'clock	3,800	L17 L206	L305
40	11 O'clock	7,150	L16 L204	L304
20	11 O'clock	14,150	L15 L205	L303
15	2 O'clock	21,450	L14 L202	L302
10	2 O'clock	29,000	L13 L203	L301

2. Loosely couple field strength meter to C54 (off pin 2 of V4) with alligator clip on ceramic capacitor body.
3. Remove screen voltage from V4 and V5 by disconnecting the wire from terminal strip immediately adjacent to V5 base, (Point A, Figure 5-2).
4. Connect VTVM across R-27, 1K resistor between pins 1 and 2 of terminal strip, using 25 volt scale. (Points B and C, Figure 5-2).

5-10 Procedure

5-11 Adjust bandswitch and P.A. GRID as shown in Table 5-2, and adjust coils for peak VTVM reading, with function switch in TUNE position:

NOTE

If VTVM and field strength meter exceed full scale reading, adjust carrier balance control to keep reading on scale. Field strength meter and VTVM must both peak at same time since it is possible to tune the coils to the VFO frequency on 10 meters. Care must be taken that the coils are tuned properly. Following the above procedures, replace screen wire to pin 5 of terminal strip adjacent to V5 (Point A, Figure 5-2).

5-12 Carrier Frequency Adjustment

1. Tune up on the 20-meter band into a dummy load. Balance out the carrier and adjust the P.A. BIAS for 50 ma.
2. Feed 1500 Hz of audio from the Audio Generator into the MIC input receptacle. Adjust the gain of the audio generator and the MIC GAIN control until the wattmeter reads between 10 and 15 watts.
3. Adjust both slugs of the Balanced Modulator transformer (T2) for maximum output.
4. Adjust the First IF coil (L32) for maximum output.
5. Increase the gain of the audio generator until the wattmeter reads 40 watts. Sweep the audio generator down to 300 Hertz. Adjust the Normal Sideband Carrier Oscillator trimmer (C170) for a reading of 10 watts.
6. Switch to Opposite Sideband and adjust carrier oscillator trimmer (C172) for 10 watt reading.
7. Re-check with audio generator set at 1500 Hz and 40 watts. Sweep down to 300 Hz and re-adjust Carrier Oscillator Trimmer capacitors, if necessary, for 10 watts output.
8. Loosely couple a frequency counter to the antenna so that a frequency reading can be made. Note the frequency with the function switch at TRANSMIT and the NORM-OPP switch at NORM. Insert carrier to obtain reading.
9. Set the function switch at CW. Connect a key to the KEY jack. Key the transmitter and adjust C171 for a frequency 800 Hz higher than noted in Step 8.

5-13 P.A. NEUTRALIZATION

5-14 With P.A. COARSE LOAD in position 1, FINE LOAD at 9 o'clock, set frequency to 14,150, P.A. PLATE control at 9 o'clock, insert carrier and peak P.A. GRID control, adjusting CAR. BAL. control for 200 ma. in CW mode. Turn P.A. PLATE control slowly through resonance. Cathode current should "dip" smoothly and rise to 200 ma. on the low capacity side of resonance. If, instead, there is a peak above 200 ma. either side of the "dip", stop rotation of the P.A. PLATE control at the peak and adjust C59 to reduce I_p to 200 ma. Repeat above check and re-adjust as necessary to obtain the desired smooth "dip". For 10 meters, use above procedure but adjust C58.

NOTE

If replacement of the power amplifier tubes is necessary, it is recommended that a matched pair of 6MJ6's be used for neutralizing purposes. A matched pair of tubes will also give longer tube life.

5-15 VFO ALIGNMENT

5-16 A trimmer condenser is provided for each VFO range. Trimmer adjustment for the five VFO ranges is through top cover of the VFO compartment. An insulated adjusting tool is recommended. Dial tracking has been factory set by pruning the coil, and will not ordinarily require further adjustment.

5-17 When the dial calibration changes beyond the adjusting range of the front panel DIAL SET control, calibration may be restored by carefully adjusting the trimmer for that range.

EXAMPLE:

The 40 meter band at 7000 KHz point is off frequency approximately 8 KHz on the high side and cannot be restored by adjusting DIAL SET on front panel.

1. Set DIAL SET at 12 o'clock position.
2. Set VFO at 7008 KHz so as to hear 100 KHz Calibrator.
3. With an insulated alignment tool in one hand and the VFO dial in the other, rotate the dial a small amount at a time down towards the 7000 KHz point, but not enough to lose the 100 KHz signal. Now rotate the trimmer so as to zero beat the 100 KHz signal. Again rotate the dial a small amount down the band so you still hear the calibrator, stop and with trimmer, zero beat the signal again. Repeat these steps until you have reached 7000 KHz point on the dial. Using caution so you do not lose the 100 KHz signal will prevent you from aligning on the wrong 100 KHz note which would put the VFO off frequency by a 100 KHz. Table 5-3 lists the actual oscillating frequency of the VFO at band edges.

5-18 FREQUENCY CALIBRATION

5-19 Frequency calibration of the HF-700-S is in 5 KHz increments on 80, 40, 20 and 15 meters, and 20 KHz increments on 10 meters. 80 meters is calibrated directly on the upper dial scale. 40, 20 and 15 meters are calibrated from zero to 450 on the center scale. "EXAMPLE": The dial is set at 200 on the center scale. (On 40 meters this would read 7.2 MHz; on 20 meters this would read 14.2 MHz, and on 15 meters this would read 21.2 MHz). 10 meters is calibrated directly on the lower dial scale. Dial accuracy and tracking are quite good on the 750-CW, but caution must always be observed when operating near band edges. Measuring the frequency with the calibrator when working near band edges is recommended.

5-20 DIAL SET

5-21 A DIAL SET control has been provided so that dial adjustment can be made at any 100 or 25 KHz point of the dial. With calibrator on, set the dial to any 100 or 25 KHz point closest to the frequency you wish to work. Now adjust control to zero-beat the VFO with the calibrator. This

Table 5-3. VFO Operating Frequencies.

Dial Frequency (KHz)	Oscillator Frequency (KHz)
3,500	9,000
3,800	9,300
4,000	9,500
7,000	12,500
7,200	12,700
7,300	12,800
14,000	8,500
14,200	8,700
14,350	8,850
21,000	15,500
21,250	15,750
21,450	15,950
28,000	22,500
28,500	23,000
29,000	23,500
29,700	24,200

provides greater accuracy of dial readout. Table 5-3 is a listing of indicated dial frequencies vs. oscillator frequencies.

CAUTION

Care must be exercised when tuning for the 100 or 25 KHz harmonics of the calibrator. Spurious image signals may be heard, although they will be somewhat weaker than the actual harmonics.

5-22 S-METER ADJUSTMENT

5-23 With antenna disconnected and with RF Gain fully clockwise, set R60, located on rear panel, for zero meter reading. Make sure no local signals are being received.

5-24 CARRIER BALANCE

5-25 A carrier balance control is provided on the front panel, and is labeled CAR. BAL. This control permits insertion of carrier during CW operation and TUNE for power control as an aid in tuning the transmitter circuits.

5-26 L25 TRAP ADJUSTMENT

5-27 Set bandswitch to 14 MHz range. Feed strong 11.9 MHz signal from signal generator into antenna jack. Tune around 14.225 MHz until signal is found. Adjust L25 for minimum signal output.

Table 5-4. Troubleshooting Guide.

DEFECT	POSSIBLE CAUSE
P.A. IDLING CURRENT UNSTABLE	<ol style="list-style-type: none"> 1. Defective 6MJ6. 2. Defective Bias Potentiometer. 3. Defective Bias Supply.
INABILITY TO LOAD TO 400-500 MA. (See Para. 3-13)	<ol style="list-style-type: none"> 1. P.A. Grid Improperly Tuned. 2. Bandswitch Improperly Set. 3. Antenna Not Resonant at Frequency. 4. Defective Transmission Line. 5. Defective Mobile Antenna Coil. 6. V2, V3, V4 or V5 Defective. 7. Resistors R31 and R32 Defective.
INSUFFICIENT CARRIER SUPPRESSION	<ol style="list-style-type: none"> 1. Carrier Balance Control Improperly Set. 2. Defective Balanced Modulator. 3. Carrier Oscillator Frequency Incorrect.
INSUFFICIENT SIDEBAND SUPPRESSION	<ol style="list-style-type: none"> 1. Excessive MIC Gain. 2. Incorrect P.A. Load Adjustment. 3. Carrier Oscillator Incorrect.
MICROPHONICS IN RECEIVER	<ol style="list-style-type: none"> 1. L901 Improperly Tuned. 2. V10, V8, V7 or V6 Defective.
LOW RECEIVER SENSITIVITY	<ol style="list-style-type: none"> 1. P.A. Grid, Plate or Load Improperly Set. 2. Bandswitch Improperly Set. 3. RY-1 Back Contacts Defective. 4. V6, V7, V8, V9, V10, V11 or V12 Defective.

5-29 CRYSTAL CALIBRATOR ADJUSTMENT

5-30 The crystal calibrator provides a means for precisely adjusting the dial calibration of the HF-700-S. However, it should occasionally be checked against WWV to insure that it has remained on frequency. If the calibrator adjustment has drifted, it can be set precisely using a tunable communications receiver tuned to WWV at 10 MHz. The procedure is outlined in the steps that follow:

1. Allow 30 minutes, or more, for the HF-700-S to warm up.
2. Loosely couple the calibrator to the input of the communications receiver by looping a wire around the calibrator crystal, Y1. (See Figure 5-2 for the location of Y1). Tune the communications receiver to WWV at 10

MHz. The beat note you hear is the beat between the crystal frequency and WWV. Zero-beat the calibrator oscillator to WWV with C148. (See Figure 5-2 for the location of C148).

5-31 CARRIER OSCILLATOR COIL ADJUSTMENT

5-32 The carrier oscillator frequency adjustment was covered in a previous paragraph. The plate coil of the carrier oscillator can be tuned separately without affecting the oscillator frequency significantly. Adjusting the carrier oscillator coil insures that the injection level is proper. The coil (L38, See Figure 5-2) is adjusted for minimum noise from the receiver output. When the output of the carrier oscillator is maximum, the harmonics of the crystal are minimized which minimizes the noise products generated in the product detector.

Table 5-5. Voltage Chart.

		1	2	3	4	5	6	7	8	9	CAP
V1 6EW6 VFO Amp.	R T	0 0	+0.75 +0.75	5.8AC 5.8AC	0 0	152 150	145 143	0 0			
V2 12BE6 Trans. Mix	R T	-109 -2.5	0 0	12.0AC 12.0AC	0 0	213 256	259 131	0 0			
V3 6GK6 Driver.	R T	0 0	-48 -8.0	0 0	6.0AC 6.0AC	0 0	0 0	290 286	290 286	0 0	877 851
V4 6MJ6 P.A.	R T	0 267	-81 -81	0 +0.07	6.0AC 6.0AC	0 0	-81 -81	0 267	0 0	0 0	877 851
V5 6MJ6 P.A.	R T	0 267	-81 -81	0 +0.07	6.0AC 6.0AC	12.0AC 12.0AC	-81 -81	0 267	0 0	0 0	877 851
V6 6CB6 R.F. Amp.	R T	-1.7 -1.8	+0.7 0	6.0AC 6.0AC	12.0AC 12.0AC	213 256	141 -26	0 0			
V7 12BE6 Rec. Mix.	R T	-2.7 -2.3	0 0	12.0AC 12.0AC	0 0	252 267	106 -26	0 -1			
V8 12BA6 1st IF	R T	-1 0	0 0	12.0AC 12.0AC	0 0	244 255	140 136	+2.5 +2.8			
V9 12BA6 2nd IF	R T	-0.2 -1.2	0 0	12.0AC 12.0AC	0 0	248 268	138 -21	+2.6 0			
V10 12AX7 Det/Amp	R T	181 113	-2.2 -2.2	0 0	0 0	0 0	162 264	-1.0 -95	0 0	6.0AC 6.0AC	
V11 6BN8 AGC/ALC Amp.	R T	0 +1.0	+2.0 +2.0	0 +1.0	6.0AC 6.0AC	12.0AC 12.0AC	-1.3 0	228 238	0 0	+2.0 +2.0	
V12 6GK6 A.F. Output	R T	0 0	-7.2 -43	0 0	12.0AC 12.0AC	6.0AC 6.0AC	0 0	276 286	256 266	0 0	
V13 12AX7 Mic. Amp.	R T	98 6S	-0.7 -0.7	0 0	6.0AC 6.0AC	6.0AC 6.0AC	0 89	0 0	0 +0.6	0 0	

See Page 18 for Test Conditions.

(Continued)

Table 5-5. Voltage Chart (Continued).

		E	C	B			E	C	B						
Q1 2N706 VFO Amp	R	-5.8	-6.5	0	Q3 2N5355 Sidetone	REC	-2.2		-12.8						
	T	-5.8	-6.5	0		CW Key Up	-2.1	-2.4	-12.8						
						CW Key Dn	-1.6	-2.2	-7.7						
Q2 2N706 VFO Buff.	R	-7.3	-6.8	0	Q4 MPS-H10 Car. Osc.	R	2.79	2.7	4.9						
	T	-7.3	-6.8	0		T	2.79	2.7	4.9						
						No Xtal	2.2	2.9	4.9						
		1	2	3	4	5	6	7	8	9	10	11	12	13	14
A1 MC1458 CW Fil.	R	3.2	3.1	3.1	0	3.1	3.1	3.2	6.2						
	T	3.2	3.1	3.1	0	3.1	3.1	3.2	6.2						
A3 7400 Cal. Osc.	OFF	0	4.0	4.0	1.3	1.3	1.1	0	3.0	1.1	1.1	0	4.9	4.9	5.0
	ON	4.1	1.1	1.1	1.1	1.1	1.1	0	1.7	1.1	1.1	1.1	0	0	5.0
A4 7490 Divider	OFF	3.0	0	0	0	5.0	0	0	0	0	0	0.1	0.1	0	0.1
	ON	1.7	0	0	0	5.0	0	0	1.7	1.6	0	0.8	2.1	0	0.8
A5 7490 Divider	OFF	0.1	0	0	0	5.0	0	0	4.1	0.1	0	4.0	0.1	0	4.0
	ON	2.1	0	0	0	5.0	0	0	1.8	1.7	0	1.0	2.1	0	1.0
A6 7474 Div. F-F	ON-100	0	0	2.2	0	0	0	0	0	0.2	0	0	0	0	0
	ON-25	1.4	2.1	2.1	1.4	2.0	2.1	0	2.1	2.0	1.4	2.1	2.1	1.4	5.0
A7 MC1496 Bal. Mod.	R	-6.7	-7.4	-7.4	-6.7	-11.6	-0.7	0	-0.1	0	0	0	-0.7	0	-12.8
	T	-6.7	-7.4	-7.4	-6.7	-11.6	-0.7	0	0	0	0	0	7.0	0	-12.8

METER: VTVM or DVM with 10 Megohm Input.

SIGNAL CONDITIONS: Receive—No Signal Input
Transmit—No Power Output

CONTROLS: CW FILTER—OFF, A.F. GAIN—100° CW, R.F. GAIN—Full CW;
BAND—3.5, MIC GAIN—Full CCW, CAR BAL—12 O'clock,
S-METER—Zeroed, P.A. BIAS—Set to 50 MA.

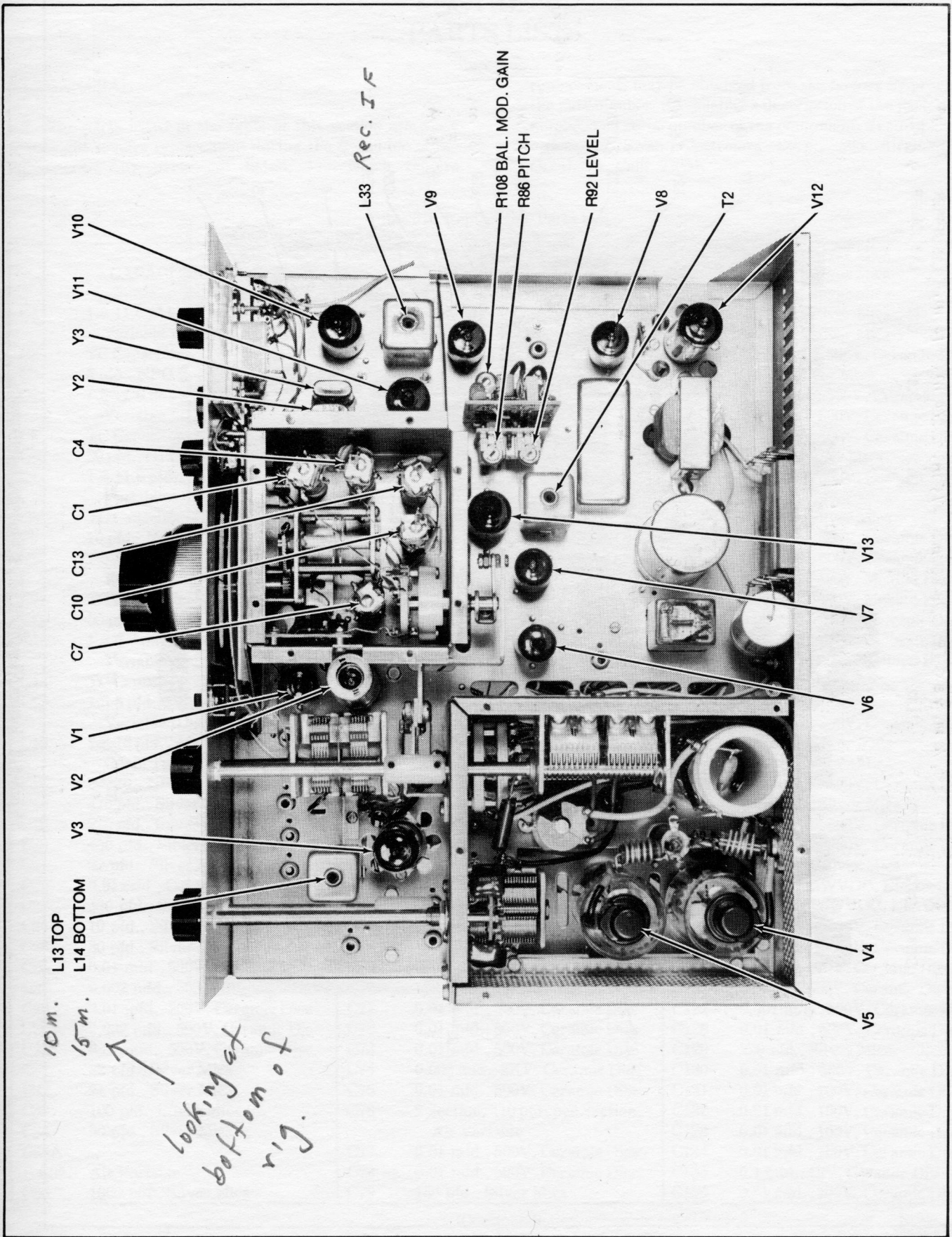

Figure 5-1. Top View of HF-700-S Showing Adjustments and Tube Locations.

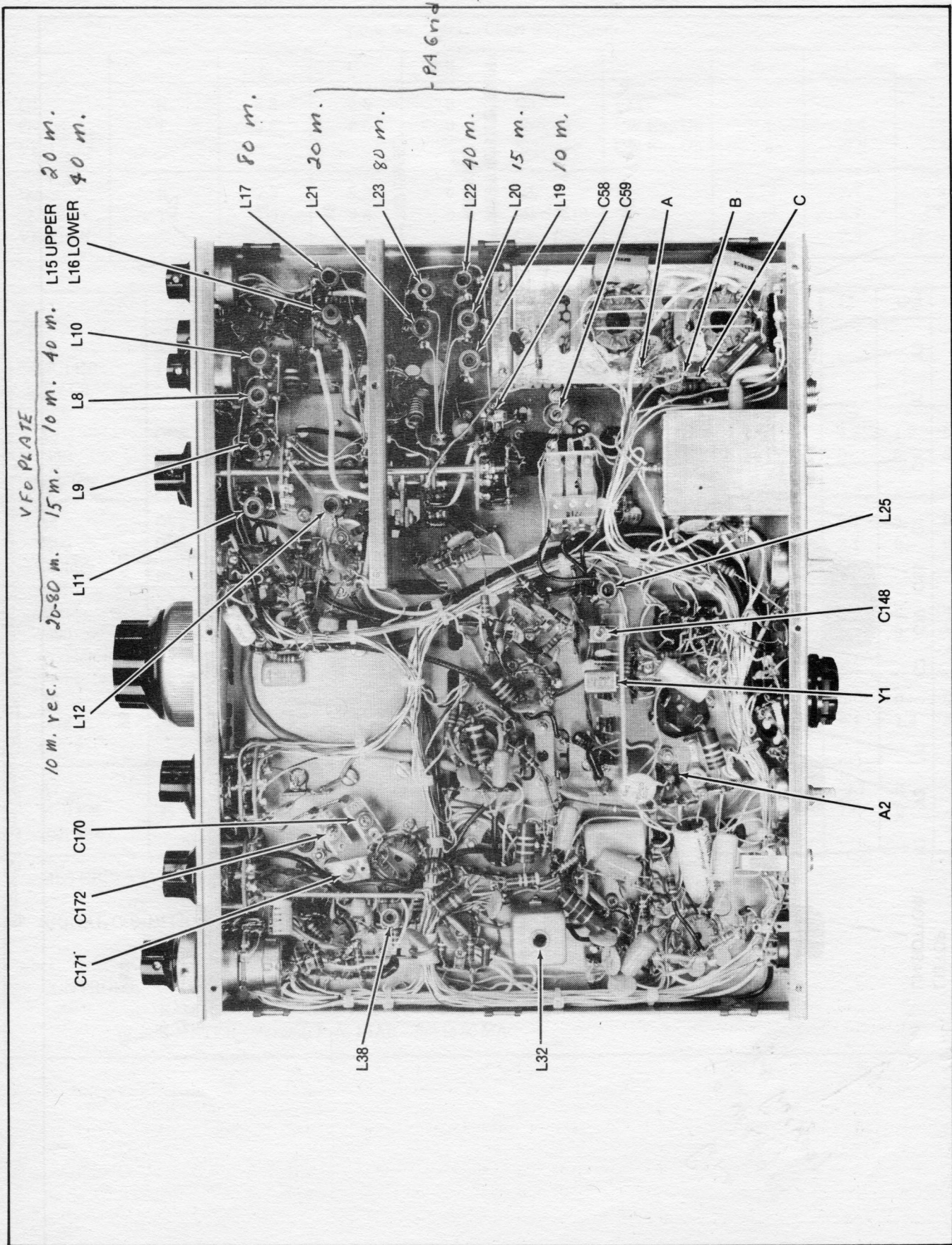
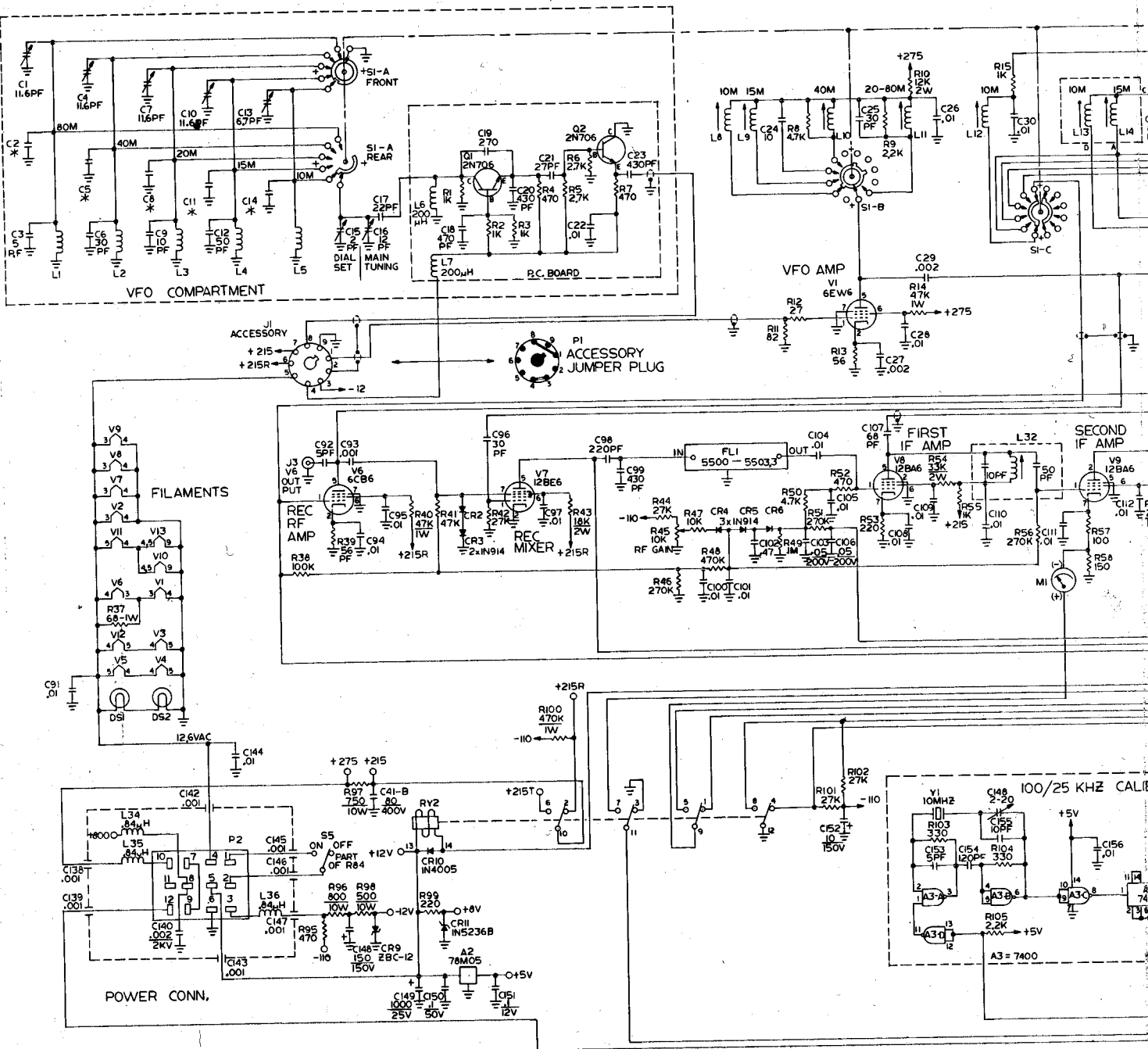

Figure 5-2. Bottom View of HF-700-S Showing Adjustments.



3. * INDICATES FACTORY SELECTED VALUES FOR TEMPERATURE COMPENSATION.
 2. RESISTANCE VALUES ARE IN OHMS.
 1. CAPACITANCE VALUES ARE IN MICROFARADS.
 NOTES: UNLESS OTHERWISE SPECIFIED

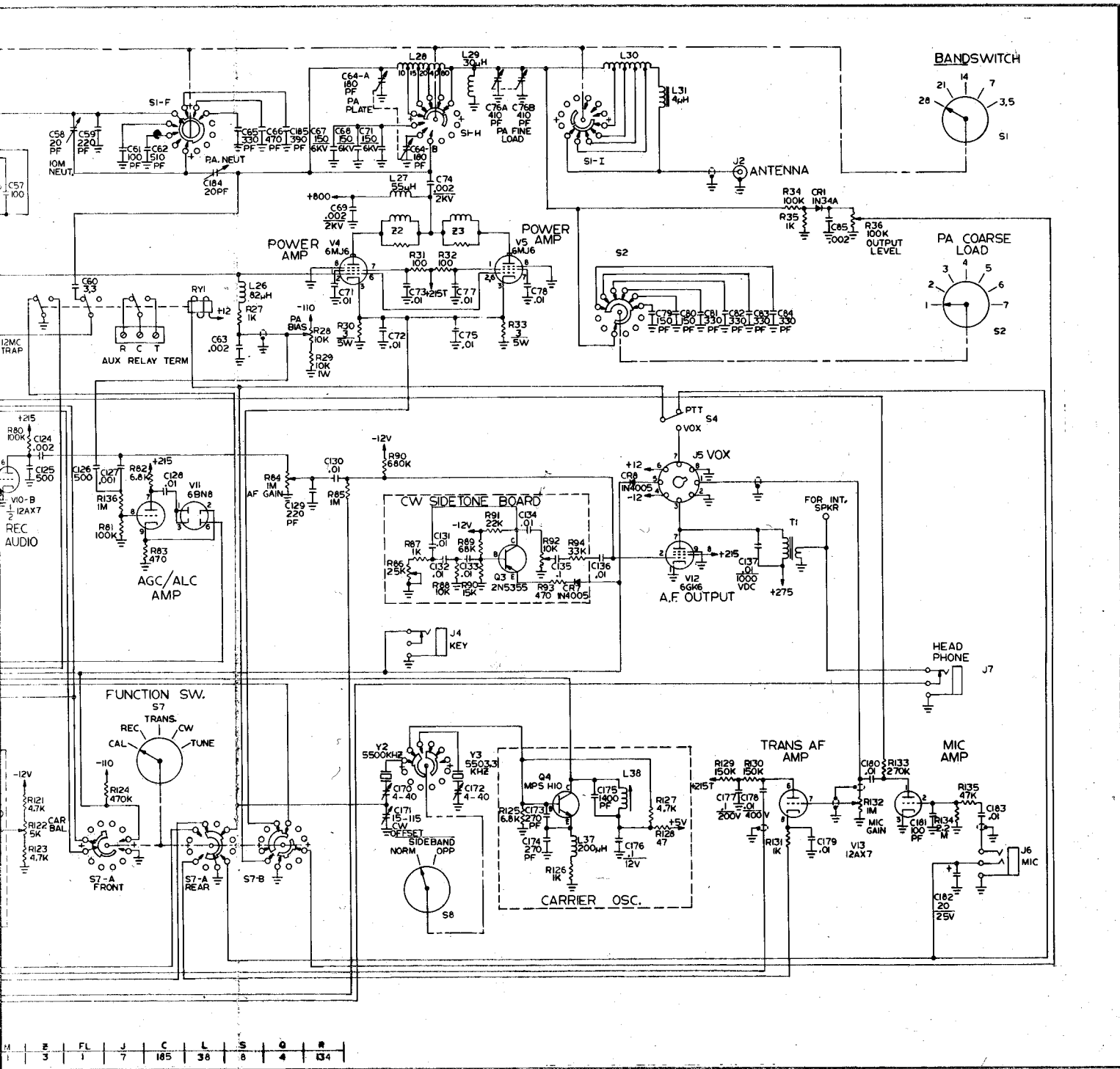

Figure 5-3. Schematic Diagram, Model HF-700-S Transceiver.

SECTION VI PARTS LISTS

6-1 GENERAL

6-2 The parts listed in the table of this section are those that might require replacement during the useful life of the equipment. Any parts not listed, but which require

replacement, may be obtained from the factory by providing the part number, if available, a description of the part, model number and serial number of the equipment. Send all factory orders to Swan Electronics Corp., 305 Airport Rd., Oceanside, Calif. 92054.

Table 6-1. Replaceable Parts List.

CAPACITORS			
C1	1.5-11.6 pfd., Miniature Air Variable	C37	50 pfd., Silver Mica
C2	TC Capacitor	C38	24 pfd., Silver Mica
C3	5 pfd., NPO	C39	20 pfd., Silver Mica
C4	1.5-11.6 pfd., Miniature Air Variable	C40	0.01 mfd., 500V, Ceramic Disc
C5	TC Capacitor	C41	80-80 mfd./450V, 20 mfd./400V Electrolytic
C6	30 pfd., NPO	C42	0.1 mfd., 200V, Molded Paper
C7	1.5-11.6 pfd., Miniature Air Variable	C43	0.002 mfd., 500V, Ceramic Disc
C8	TC Capacitor	C44	4.7 mfd., Silver Mica
C9	10 pfd., NPO	C45	50 pfd., Silver Mica
C10	1.5-11.6 pfd., Miniature Air Variable	C46	100 pfd., Silver Mica
C11	TC Capacitor	C47	0.01 mfd., 500V, Ceramic Disc
C12	50 pfd., NPO	C48	50 pfd., Silver Mica
C13	1.3-6.7 pfd., Miniature Air Variable	C49	50 pfd., Silver Mica
C14	TC Capacitor	C50	0.002 mfd., 500V, Ceramic Disc
C15	1.5-5 pfd., Miniature Air Variable (Dial Set)	C51	0.01 mfd., 500V, Ceramic Disc
C16	1.8-13 pfd., Air Variable (Main Tuning)	C52	0.01 mfd., 500V, Ceramic Disc
C17	22 pfd., NPO	C53	270 pfd., Silver Mica
C18	470 pfd., Silver Mica	C54	0.002 mfd., 500V, Ceramic Disc
C19	270 pfd., Silver Mica	C55	12 pfd., Silver Mica
C20	430 pfd., Silver Mica	C56	27 pfd., Silver Mica
C21	27 pfd., Silver Mica	C57	100 pfd., Silver Mica
C22	0.01 mfd., Ceramic Disc	C58	20 pfd., Air Variable
C23	430 pfd., Silver Mica	C59	220 pfd., Silver Mica
C24	10 pfd., Silver Mica	C60	3.3 pfd., Miniature, 10%, Type QC
C25	30 pfd., Silver Mica	C61	100 pfd., Silver Mica
C26	0.01 mfd., 500V, Ceramic Disc	C62	510 pfd., Silver Mica
C27	0.002 mfd., 500V, Ceramic Disc	C63	0.002 mfd., 500V, Ceramic Disc
C28	0.01 mfd., 500V, Ceramic Disc	C64	2 Section, 180 pfd. per Section, Air Variable
C29	0.002 mfd., 500V, Ceramic Disc	C65	330 pfd., Silver Mica
C30	0.01 mfd., 500V, Ceramic Disc	C66	390 pfd., Silver Mica
C31	82 pfd., Silver Mica	C67	150 pfd., 6KV, Ceramic Disc
C32	24 pfd., Silver Mica	C68	150 pfd., 6KV, Ceramic Disc
C33	100 pfd., Silver Mica	C69	0.002 mfd., 2KV, Ceramic Disc
C34	50 pfd., Silver Mica	C70	150 pfd., 6KV, Ceramic Disc
C35A-		C71	0.01 mfd., 500V, Ceramic Disc
C35B	Air Variable	C72	0.01 mfd., 500V, Ceramic Disc
C36	1000 pfd., Silver Mica	C73	0.01 mfd., 500V, Ceramic Disc
		C74	0.002 mfd., 2KV, Ceramic Disc
		C75	0.01 mfd., 500V, Ceramic Disc
		C76	2 Section, 410 pfd. per Section, Air Variable
		C77	0.01 mfd., 500V, Ceramic Disc
		C78	0.01 mfd., 500V, Ceramic Disc
		C79	150 pfd., Silver Mica
		C80	150 pfd., Silver Mica
		C81	330 pfd., Silver Mica
		C82	330 pfd., Silver Mica
		C83	330 pfd., Silver Mica
		C84	330 pfd., Silver Mica
		C85	0.002 mfd., 500V, Ceramic Disc
		C92	5 pfd., Silver Mica
		C93	0.001 mfd., 500V, Ceramic Disc
		C94	0.01 mfd., 500V, Ceramic Disc
		C95	0.01 mfd., 500V, Ceramic Disc
		C96	30 pfd., Silver Mica
		C97	0.01 mfd., 500V, Ceramic Disc
		C98	220 pfd., Silver Mica
		C99	430 pfd., Silver Mica
		C100	0.01 mfd., 500V, Ceramic Disc
		C101	0.01 mfd., 500V, Ceramic Disc
		C102	0.47 mfd., 450V, Molded Paper
		C103	0.05 mfd., 200V, Molded Paper
		C104	0.01 mfd., 500V, Ceramic Disc
		C105	0.01 mfd., 500V, Ceramic Disc
		C106	0.05 mfd., 200V, Molded Paper
		C107	68 pfd., Silver Mica
		C108-	
		C113	0.01 mfd., 500V, Ceramic Disc
		C114	150 pfd., Silver Mica
		C115	220 pfd., Silver Mica
		C116	0.002 mfd., 500V, Ceramic Disc
		C117	1000 pfd., Silver Mica
		C118	0.001 mfd., 500V, Ceramic Disc
		C119	0.001 mfd., 500V, Ceramic Disc
		C120	1000 pfd., Silver Mica
		C121	33 mfd., 25WVDC, Electrolytic
		C122	100 mfd., 25WVDC, Electrolytic
		C123	0.002 mfd., 500V, Ceramic Disc
		C124	0.002 mfd., 500V, Ceramic Disc
		C125	500 pfd., 500V, Ceramic Disc
		C126	500 pfd., 500V, Ceramic Disc
		C127	0.001 mfd., 500V, Ceramic Disc
		C128	0.01 mfd., 500V, Ceramic Disc
		C129	220 pfd., Silver Mica
		C130	0.01 mfd., 500V, Ceramic Disc
		C131	0.01 mfd., 100V, Ceramic Disc
		C132	0.01 mfd., 100V, Ceramic Disc
		C133	0.01 mfd., 100V, Ceramic Disc
		C134	0.01 mfd., 100V, Ceramic Disc
		C135	0.1 mfd., 12V, Ceramic Disc
		C136	0.01 mfd., 100V, Ceramic Disc

(Continued)

Table 6-1. (Continued)

		COILS		RESISTORS	
C138	0.001 mfd., 1000V, Feedthru	L1	80 Meter, VFO	R1	1K Ohms, 1/2 Watt, 10%
C139	0.001 mfd., 1000V, Feedthru	L2	40 Meter, VFO	R2	1K Ohms, 1/2 Watt, 10%
C140	0.002 mfd., 2KV, Ceramic Disc	L3	20 Meter, VFO	R3	1K Ohms, 1/2 Watt, 10%
C142	0.001 mfd., 1000V, Feedthru	L4	15 Meter, VFO	R4	470 Ohms, 1/2 Watt, 10%
C143	0.001 mfd., 1000V, Feedthru	L5	10 Meter, VFO	R5	2.7K Ohms, 1/2 Watt, 10%
C144	0.01 mfd., 500V, Ceramic Disc	L6	200 uhy, RFC	R6	2.7K Ohms, 1/2 Watt, 10%
C145	0.001 mfd., 1000V, Feedthru	L7	200 uhy, RFC	R7	470 Ohms, 1/2 Watt, 10%
C146	0.001 mfd., 1000V, Feedthru	L8	10 Meter, VFO, Amp	R8	4.7K Ohms, 1/2 Watt, 10%
C147	0.001 mfd., 1000V, Feedthru	L9	15 Meter, VFO, Amp	R9	2.2K Ohms, 1/2 Watt, 10%
C148	150 mfd., 150V, Electrolytic	L10	40 Meter, VFO, Amp	R10	12K Ohms, 2 Watt, 10%
C149	1000 mfd., 25V, Electrolytic	L11	20-80 Meter, VFO, Amp	R11	82 Ohms, 1/2 Watt, 10%
C150	0.1 mfd., 50V, Ceramic Disc	L12	10 Meter, Receiver Coil	R12	27 Ohms, 1/2 Watt, 10%
C151	0.1 mfd., 12V, Ceramic Disc	L13	10 Meter, Transmit Mixer	R13	56 Ohms, 1/2 Watt, 10%
C152	10 mfd., 150V, Electrolytic	L14	15 Meter, Transmit Mixer	R14	47K Ohms, 1 Watt, 10%
C153	5 pfd., Silver Mica	L15	20 Meter, Transmit Mixer	R15	1K Ohms, 1/2 Watt, 10%
C154	120 pfd., Silver Mica	L16	40 Meter, Transmit Mixer	R16	6.8K Ohms, 1/2 Watt, 10%
C155	10 pfd., Silver Mica	L17	80 Meter, Transmit Mixer	R17	15K Ohms, 1/2 Watt, 10%
C156	0.01 mfd., 100V, Ceramic Disc	L18	200 uhy, RFC	R18	4.7K Ohms, 1 Watt, 10%
C157	0.01 mfd., 100V, Ceramic Disc	L19	10 Meter, Driver	R19	27K Ohms, 1/2 Watt, 10%
C158	Not Physical Capacitor, Gimmick Coupling	L20	15 Meter, Driver	R20	27K Ohms, 1/2 Watt, 10%
C159	Not Physical Capacitor, Gimmick Coupling	L21	20 Meter, Driver	R21	18K Ohms, 2 Watt, 10%
C160	0.01 mfd., 500V, Ceramic Disc	L22	40 Meter, Driver	R22	270K Ohms, 1/2 Watt, 10%
C161	0.001 mfd., 500V, Ceramic Disc	L23	80 Meter, Driver	R23	220K Ohms, 1/2 Watt, 10%
C162	0.001 mfd., 500V, Ceramic Disc	L24	200 uhy, RFC	R24	10K Ohms, 1/2 Watt, 10%
C163	0.1 mfd., 100V, Ceramic Disc	L25	12 MHz, Trap	R25	8.2K Ohms, 1/2 Watt, 10%
C164	100 pfd., Silver Mica	L26	82 uhy, RFC	R26	100 Ohms, 1/2 Watt, 10%
C165	0.001 mfd., 500V, Ceramic Disc	L27	55 uhy, RFC	R27	1K Ohms, 1/2 Watt, 10%
C166	0.001 mfd., 500V, Ceramic Disc	L28	Pi Section, Plate Tank	R28	10K Ohms, Linear Taper, W.W. Potentiometer
C167	0.001 mfd., 500V, Ceramic Disc	L29	30 uhy, RFC	R29	10K Ohms, 1 Watt, 10%
C168	0.001 mfd., 500V, Ceramic Disc	L30	L Section, Plate Tank	R30	30 Ohms, 5 Watt, 10%, W.W.
C169	33 mfd., 25V, Electrolytic	L31	4 uhy, Toroid	R31	100 Ohms, 1/2 Watt, 10%
C170	4-40 pfd., Mica Compression Trimmer	L32	First IF Amplifier	R32	100 Ohms, 1/2 Watt, 10%
C171	15-115 pfd., Mica Compression Trimmer	L33	Second IF Amplifier	R33	3 Ohms, 5 Watt, 10%, W.W.
C172	4-40 pfd., Mica Compression Trimmer	L34	0.84 uhy, RFC	R34	100K Ohms, 1/2 Watt, 10%
C173	270 pfd., Silver Mica	L35	0.84 uhy, RFC	R35	1K Ohms, 1/2 Watt, 10%
C174	270 pfd., Silver Mica	L36	0.84 uhy, RFC	R36	100K Ohms, Linear Taper Potentiometer
C175	1400 pfd., Silver Mica	L37	200 uhy, RFC	R37	68 Ohms, 1 Watt, 10%
C176	0.1 mfd., 12V, Ceramic Disc	L38	Carrier Oscillator	R38	100K Ohms, 1/2 Watt, 10%
C177	0.1 mfd., 200V, Molded Paper			R39	56 Ohms, 1/2 Watt, 10%
C178	0.01 mfd., 400V, Molded Paper			R40	47K Ohms, 1 Watt, 10%
C179	0.01 mfd., 500V, Ceramic Disc			R41	47K Ohms, 1/2 Watt, 10%
C180	0.01 mfd., 500V, Ceramic Disc			R42	27K Ohms, 1/2 Watt, 10%
C181	100 pfd., Silver Mica			R43	18K Ohms, 2 Watt, 10%
C182	20 mfd., 25V, Electrolytic			R44	27K Ohms, 1/2 Watt, 10%
C183	0.01 mfd., 500V, Ceramic Disc			R45	10K Ohms, Reverse 5% C Taper RF Gain, (P/O AF Gain and Power Switch)
C184	20 pfd., Mica Compression Trimmer			R46	270K Ohms, 1/2 Watt, 10%
C185	390 pfd., Silver Mica			R47	10K Ohms, 1/2 Watt, 10%
				R48	470K Ohms, 1/2 Watt, 10%
				R49	1M Ohms, 1/2 Watt, 10%
				R50	4.7K Ohms, 1/2 Watt, 10%
				R51	270K Ohms, 1/2 Watt, 10%

(Continued)

Table 6-1. (Continued)

R52	470 Ohms, 1/2 Watt, 10%	R107	27K Ohms, 2 Watt, 5%		
R53	220 Ohms, 1/2 Watt, 10%	R108	500 Ohms, Linear Taper, PC Mount Potentiometer		CRYSTALS
R54	33K Ohms, 2 Watt, 10%	R109	4.7K Ohms, 1/4 Watt, 5%	Y1	10 MHz, Series Resonant, HC-18/U
R55	1K Ohms, 1/2 Watt, 10%	R110	4.7K Ohms, 1/4 Watt, 5%	Y2	5500 KHz, Parallel Resonant, 32 pfd., HC-6/U
R56	270K Ohms, 1/2 Watt, 10%	R111	10K Ohms, 1/4 Watt, 5%	Y3	5503.3 KHz, Parallel Resonant, 32 pfd., HC-6/U
R57	100 Ohms, 1/2 Watt, 10%	R112	6.8K Ohms, 1/4 Watt, 5%		TUBES
R58	150 Ohms, 1/2 Watt, 10%	R113	6.8K Ohms, 1/4 Watt, 5%	V1	6EW6
R59	27K Ohms, 1 Watt, 10%	R114	6S0 Ohms, 1/4 Watt, 5%	V2	12BE6
R60	1K Ohms, Wirewound	R115	470 Ohms, 1/4 Watt, 5%	V3	6GK6
R61	100K Ohms, 1/2 Watt, 10%	R116	4.7K Ohms, 1/4 Watt, 5%	V4	6MJ6
R62	1K Ohms, 1/2 Watt, 10%	R117	470 Ohms, 1/4 Watt, 5%	V5	6MJ6
R63	1K Ohms, 1/2 Watt, 10%	R118	4.7K Ohms, 1/4 Watt, 5%	V6	6CB6
R64	10K Ohms, 1/2 Watt, 10%	R119	15K Ohms, 1/4 Watt, 5%	V7	12BE6
R65	47K Ohms, 1/2 Watt, 10%	R120	4.7K Ohms, 1/4 Watt, 5%	V8	12BA6
R66	270 Ohms, 1/2 Watt, 10%	R121	4.7K Ohms, 1/2 Watt, 10%	V9	12BA6
R67	270K Ohms, 1/2 Watt, 10%	R122	5K Ohms, Linear Taper, Potentiometer	V10	12AX7
R68	910K Ohms, 1/2 Watt, 10%	R123	4.7K Ohms, 1/2 Watt, 10%	V11	6BN8
R69	22K Ohms, 1/4 Watt, 5%	R124	470K Ohms, 1/2 Watt, 10%	V12	6GK6
R70	1.8M Ohms, 1/4 Watt, 5%	R125	6.8K Ohms, 1/4 Watt, 5%	V13	12AX7
R71	910K Ohms, 1/4 Watt, 5%	R126	1K Ohms, 1/4 Watt, 5%		SWITCHES
R72	22K Ohms, 1/4 Watt, 5%	R127	4.7K Ohms, 1/4 Watt, 5%	S1	Bandswitch
R73	1K Ohms, 1/4 Watt, 5%	R128	47 Ohms, 1/4 Watt, 5%	S2	Coarse Load
R74	1.8M Ohms, 1/4 Watt, 5%	R129	150K Ohms, 1/2 Watt, 10%	S3	3P3T Paddle, CW Filter
R75	1K Ohms, 1/4 Watt, 5%	R130	150K Ohms, 1/2 Watt, 10%	S4	SPDT Paddle, VOX/PTT
R76	220 Ohms, 1/4 Watt, 5%	R131	1K Ohms, 1/2 Watt, 10%	S5	Power, Part of R84
R77	47K Ohms, 1/2 Watt, 10%	R132	1 Megohm, Audio Taper Potentiometer	S6	Calibrator, SPDT Paddle
R78	1M Ohms, 1/2 Watt, 10%	R133	270K Ohms, 1/2 Watt, 10%	S7	Function
R79	10M Ohms, 1/2 Watt, 10%	R134	2.2M Ohms, 1/2 Watt, 10%	S8	Sideband Selector
R80	100K Ohms, 1/2 Watt, 10%	R135	47K Ohms, 1/2 Watt, 10%		CONNECTORS
R81	100K Ohms, 1/2 Watt, 10%	R136	1M Ohms, 1/2 Watt, 10%	J1	9 Pin Socket, Accessory
R82	6.8K Ohms, 1/2 Watt, 10%			J2	SO-239, Antenna
R83	470 Ohms, 1/2 Watt, 10%		TRANSISTORS	J3	RCA Phono Jack, V6 Output
R84	1 Megohm, A Taper, Potentiometer, AF Gain	Q1	2N706	J4	1/4 Inch Phone Jack, Shorting, Key Jack
R85	1M Ohms, 1/2 Watt, 10%	Q2	2N706	J5	Octal Socket, VOX
R86	25K Ohms, PC Mount, Linear Taper Potentiometer	Q3	2N5355	J6	1/4 Inch Microphone Jack
R87	1K Ohms, 1/4 Watt, 5%	Q4	MPS-H-10	J7	1/4 Inch Phone Jack Shorting, Headphones
R88	10K Ohms, 1/4 Watt, 5%			P1	Pin, Accessory Jumper Plug
R89	68K Ohms, 1/4 Watt, 5%		INTEGRATED CIRCUITS	P2	12-Pin Jones Plug, Power
R90	15K Ohms, 1/4 Watt, 5%	A1	MC1458P1		MISCELLANEOUS
R91	22K Ohms, 1/4 Watt, 5%	A2	78M05	FL1	6 Pole Crystal Lattice Filter, 5500 KHz, 2.7 KHz BW
R92	10K Ohms, PC Mount, Linear Taper Potentiometer	A3	7400	M1	Meter, 0-1 MA
R93	470 Ohms, 1/4 Watt, 5%	A4	7490	RY1	Relay, 3PDT, 12VDC
R94	33K Ohms, 1/4 Watt, 5%	A5	7490	RY2	Relay, 4PDT, 12VDC
R95	470 Ohms, 1/2 Watt, 10%	A6	7474	Z1	Network, Parasitic Suppressor
R96	800 Ohms, 10 Watt, 10%	A7	MC1496P	Z2	Network, Parasitic Suppressor
R97	750 Ohms, 10 Watt, 10%			Z3	Network, Parasitic Suppressor
R98	500 Ohms, 10 Watt, 10%		TRANSFORMERS		
R99	220 Ohms, 1/2 Watt, 10%	T1	Audio Output		
R100	470K Ohms, 1 Watt, 10%	T2	Balanced Modulator		
R101	27K Ohms, 1/2 Watt, 10%				
R102	27K Ohms, 1/2 Watt, 10%				
R103	330 Ohms, 1/4 Watt, 5%				
R104	330 Ohms, 1/4 Watt, 5%				
R105	2.2K Ohms, 1/4 Watt, 5%				
R106	1K Ohms, 1/2 Watt, 10%				

SWAN MODELS PSU-3 AND PSU-4 POWER SUPPLIES

GENERAL DESCRIPTION

The Swan Models PSU-3 and PSU-4 fixed station power supplies are designed to provide all the voltages necessary for operation of Swan vacuum tube type radio transceivers. The PSU-3 provides power for Swan amateur radio transceiver Model 240, those models in the 250 and 350 series, Model 400 and those models in the 500 and 700 series. The PSU-4 provides power for Swan commercial radio transceivers with model numbers in the 300 and 400 series. The PSU-3 and PSU-4 are housed in enclosures that are styled to match Swan transceivers and are finished complete with AC line cord, interconnect cable and a panel mounted power indicator light. In addition, the PSU-3 is equipped with a 5 inch oval speaker and a head-phone jack.

The PSU-3 and PSU-4 are supplied from the factory with internal input connections for 117 VAC, 50 to 60 Hz operation. The schematic diagram and illustration of the input power terminal strip, which are reproduced on the reverse of this sheet, show the internal connections for 230 VAC, 50 to 60 Hz operation. The procedure for reconnection for 230 VAC operation is detailed in the paragraph on installation and can be easily accomplished in the field.

ELECTRICAL DESIGN

The Models PSU-3 and PSU-4 are conservatively designed for long life and reliable service when used with the Swan transceivers of the models listed above. Service, when required, is easily accomplished as all components are readily accessible and may be tested and replaced in a minimum of time. The circuits are quite conventional using silicon bridge rectifiers for the high voltage sources and single silicon rectifiers for the low voltage, negative bias supply and positive relay supply. Two primary windings on the power transformer are connected in parallel for 117 VAC operation and in series for 230 VAC operation. A three foot long, multiconductor cable, equipped with a connector that mates with the power connector of the associated transceiver provides for interconnection of the two units.

INSTALLATION

117 VAC Operation

For 117 VAC operation, installation requires that the connector on the end of the multiconductor cable of the power supply be pushed onto the mating connector of the radio transceiver. The line cord is then plugged into the wall receptacle. The front panel power switch on the radio transceiver will then control application of power to the primary windings of the power supply transformer.

230 VAC Operation

To operate the PSU-3 or PSU-4 from a 230 VAC source, it is necessary to reconnect the transformer primary winding connections. The cover must be removed and is accomplished by removing three screws on each side of the unit that attach the cover. Then, lift the cover from the unit.

CAUTION

The PSU-3 and PSU-4 power supplies use and generate electrical voltages that are dangerous to life. Verify that the line cord is removed from the wall receptacle whenever the cover is to be removed. Dangerous voltages are present when the line cord is plugged in whether the power switch on the associated transceiver is in the ON or OFF position.

Remove the screw from the bottom of the chassis and two from the rear panel that attach the circuit board to the chassis. Gently pull the board forward and outward to provide easy access to the input power terminal strip mounted on the chassis. Disconnect the transformer input wires from the terminal strip and reconnect them as shown in Figure 1 on the reverse page.

CAUTION

One of the brown wires from the front panel neon indicator lamp must be connected to the orange transformer lead and the other to the brown transformer lead as shown in the schematic diagram and in Figure 1. This connection provides 117 VAC to the indicator. If the indicator is connected to 230 VAC, it will be destroyed.



Reinstall the circuit board and cover using the hardware that was removed. Replace the 6 ampere fuse with a 3 ampere fuse. Push the connector on the end of the multiconductor cable onto the mating connector of the associated transceiver. The line cord can then be plugged into the wall receptacle.

NOTE

It may be necessary to replace the line cord connector with another that mates with a polarized 230 VAC wall receptacle.

OPERATION

There are no special operational procedures for the PSU-3 and PSU-4 power supplies. Primary power application to the power supply transformer will be controlled by the front panel POWER switch on the associated radio transceiver and the audio level from the speaker of the PSU-3 will be controlled by the VOLUME control of the transceiver. Inserting a headphone plug in the phone jack of the PSU-3 will disconnect the speaker and the headphone volume will be controlled by the VOLUME control of the transceiver.

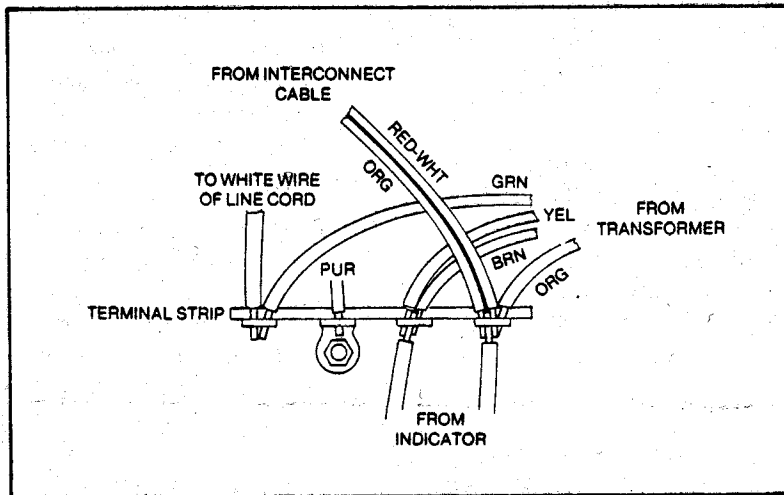

Figure 1. Connections for 230 VAC Operation.

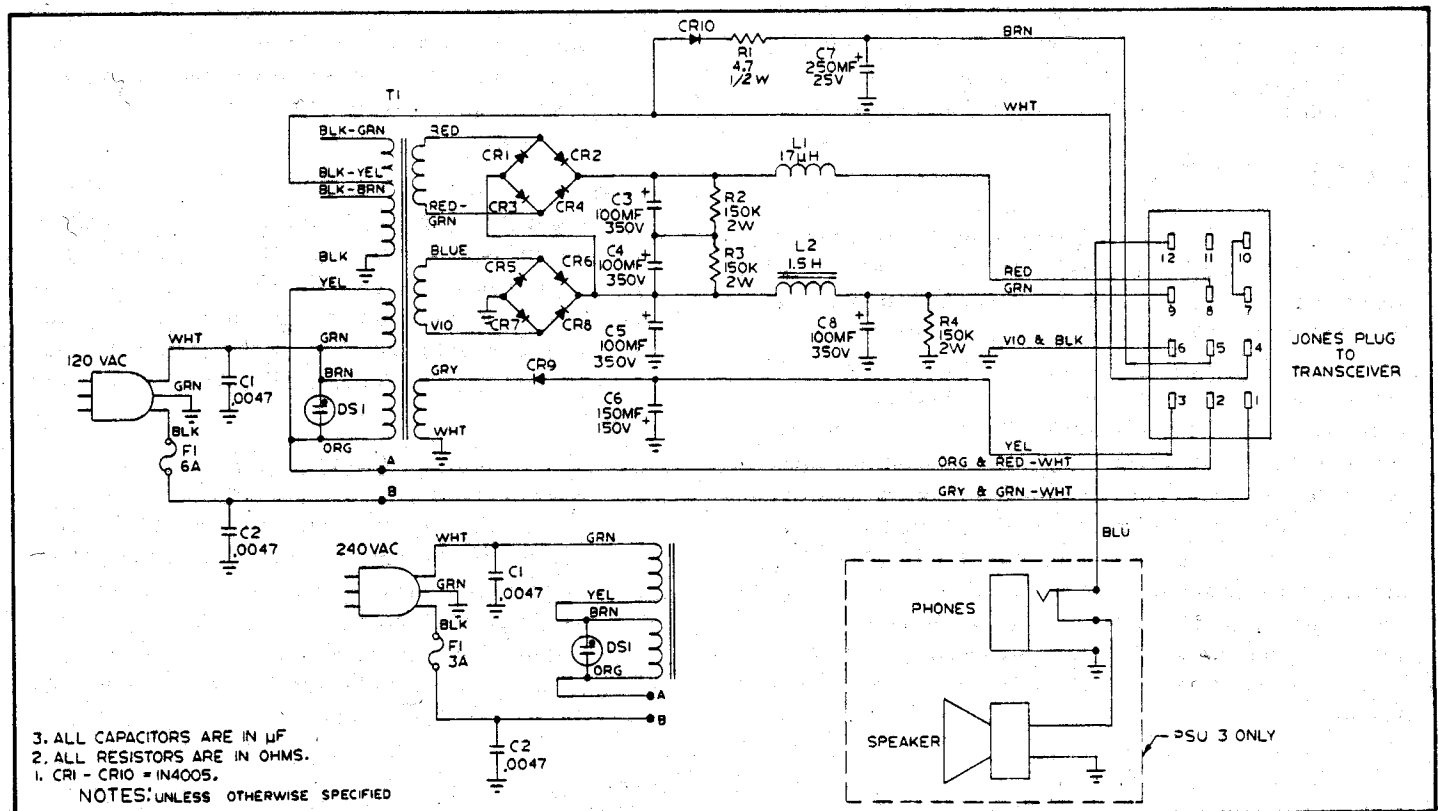

Figure 2. Schematic Diagram.

WARRANTY POLICY

Swan Electronics Corporation warrants this equipment against defects in material or workmanship, except for tubes and solid-state devices, under normal service for a period of one year from original purchase date. Tubes and solid-state devices are warranted for a period of ninety (90) days. This warranty is valid only if the enclosed warranty registration card is properly completed and mailed to the factory within ten (10) days of purchase date.

If warranty service is required, do not ship equipment to the factory without prior authorization obtained from Swan Electronics Corporation. This warranty is limited to repairing or replacing the defective parts only and is not valid if the equipment has been tampered with, misused or damaged.

Liability for damage during shipment lies with the carrier and not with Swan Electronics Corporation. Any claims/adjustments for shipping damages must be filed directly with the carrier. This warranty contains the entire obligation of Swan Electronics Corporation and no other warranties expressed or implied or statutory are given. In no event shall Swan Electronics Corporation be liable for consequential damages.



305 Airport Road • Oceanside, CA 92054 • Phone (714) 757-7525